



# BAB 2 TEKANAN





## 2. TEKANAN

## 2. PRESSURE

### 2.1 Tekanan Cecair

### 2.1 Liquid Pressure

A2007

A2021

A2018

B2017

### 2.2 Tekanan Atmosfera

### 2.2 Atmospheric Pressure

A2014

C2012

C2009

### 2.3 Tekanan Gas

### 2.3 Gas Pressure

### 2.4 Prinsip Pascal

### 2.4 Pascal's Principle

A2008

B2017

B2011

B2009

### 2.5 Prinsip Archimedes

### 2.5 Archimedes' Principle

A2013

A2009

A2003

A2019

A2022

C2005

C2010

C2016

### 2.6 Prinsip Bernoulli

### Bernoulli's Principle

A2020

A2017

A2006

B2013

C2007

C2015

C2021

**Section A - 2007**

2. Rajah menunjukkan sebuah tangki air yang membekalkan air ke sebuah blok rumah pangsa. Air mengalir ke setiap rumah itu disebabkan oleh tekanan air.

*Diagram 2 shows a water tank that supplies water to a block of flats. The water flows to each unit of the flat due to water pressure.*

a. Apakah yang dimaksudkan dengan tekanan?  
*What is meant by pressure?*

.....  
[1 m]

b. Tangki air setinggi 3.0 m diisi penuh dengan air. Hitung tekanan air pada dasar tangki itu.  
[Ketumpatan air = 1 000 kg m<sup>-3</sup>]

*A water tank with a height of 3.0 m is fully filled with water. Calculate the water pressure at the base of the water tank.*

*[Density of water = 1 000 kgm<sup>-3</sup>]*

**$P = 1000 \times 10 \times 3 = 30\,000 \text{ Pa}$**  [2 m]

**Force**  
**Area**  
**Daya**  
**luas**

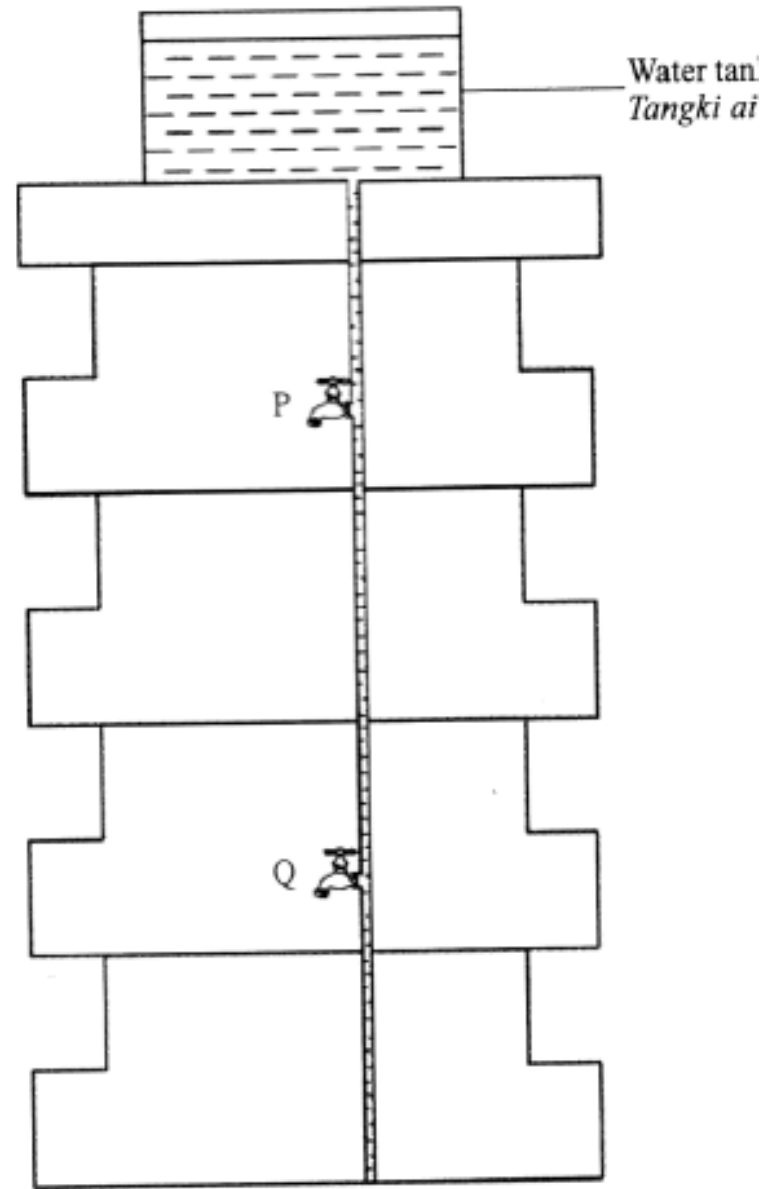

- c. Berdasarkan Rajah 2, bandingkan tekanan di P dengan tekanan di Q. Jelaskan jawapan anda.

*Based on Diagram 2, compare the water pressure at P and at Q. Explain your answer.*

.....  
[2 m]

- 1- Pressure at Q is higher //  $P_Q > P_P$**   
**2- Depth at Q is higher**



### Soalan 1(2)

Rajah 1 menunjukkan satu tiub digunakan untuk mengalirkan air dari akuarium ke dalam baldi.

Diagram 1 shows a tube used to flow out the water from an aquarium into a pail.

**Section A - 2021**

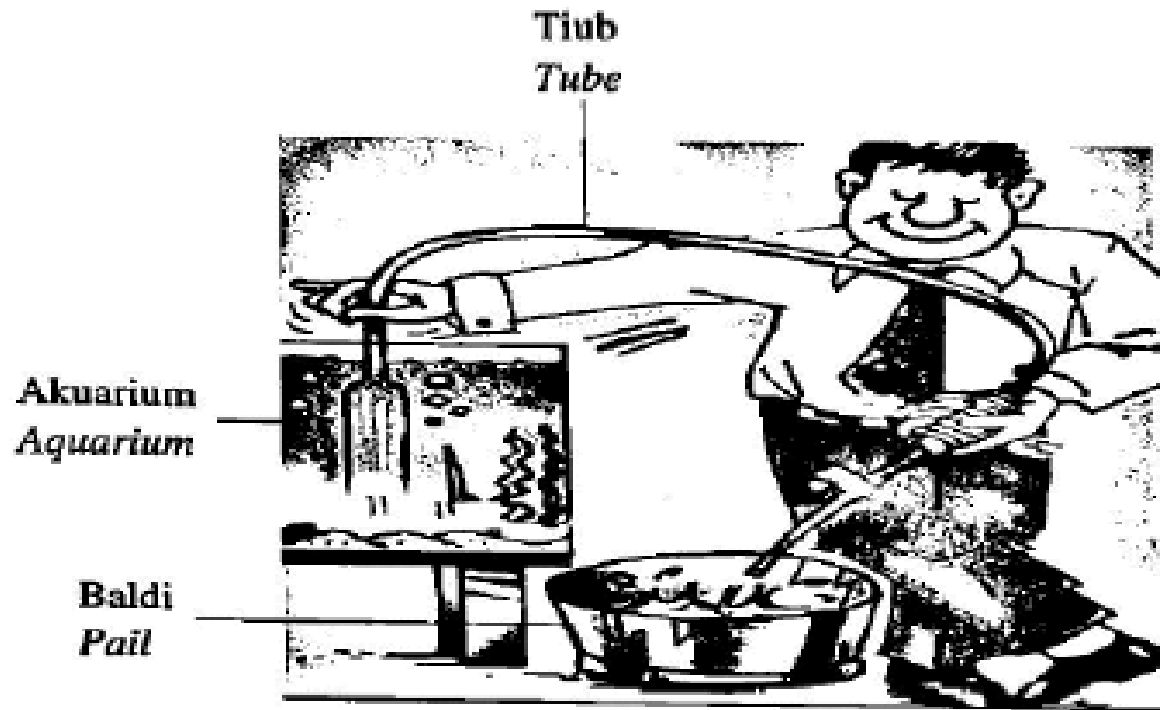

(a) Berdasarkan Rajah 1, namakan kaedah yang digunakan.

*Based on Diagram 1, name the method used.*

**Sifon / Siphone**

**Reject ejaan salah**

[1 markah]



(b) Apakah kuantiti fizik yang menyebabkan air mengalir keluar dari akuarium?

*What is the physical quantity that causes water to flow out from the aquarium?*

**Tekanan (dalam bendalir) / tekanan atmosfera**  
**/ tekanan / pressure in liquid / atmospheric pressure / pressure**

**Reject symbol  $P$  /  $P_{atm}$**

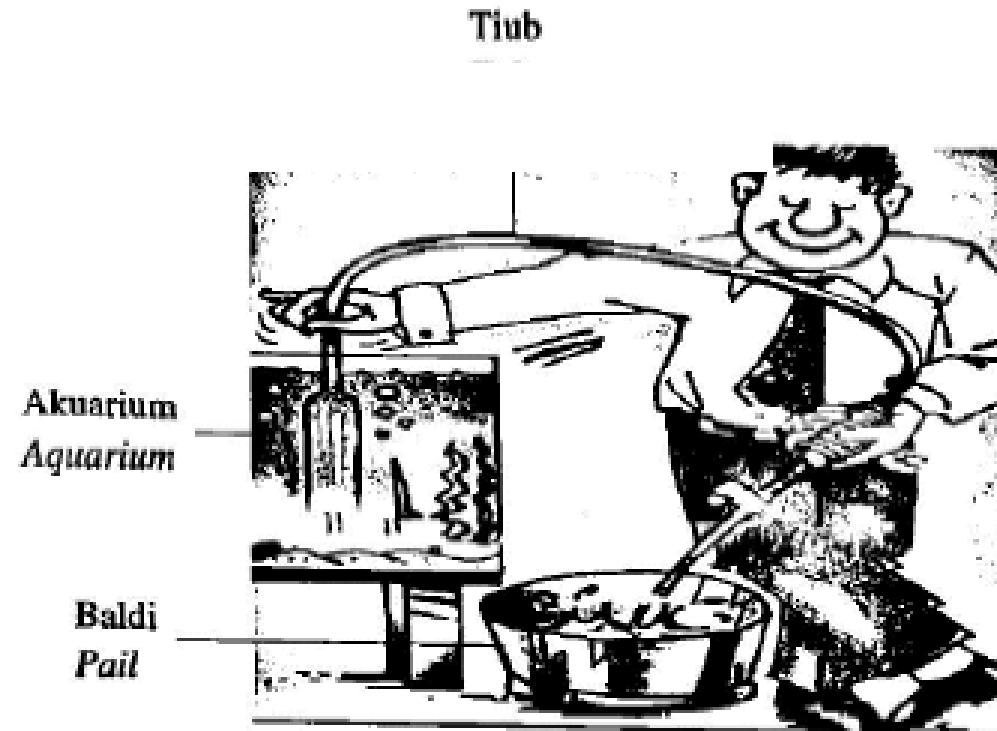

- (c) Gariskan perkataan yang betul.  
Underline the correct word.

Kadar pemindahan air dapat ditingkatkan  
dengan

Rate of water transfer can be increased by

- (i) (mengurangkan, menambahkan) diameter  
tiub.

(reduce, increase) the diameter of the  
tube.

- (ii) (merendahkan, meninggikan) kedudukan  
baldi.

(lower, higher) the position of the pail.

[2 markah]

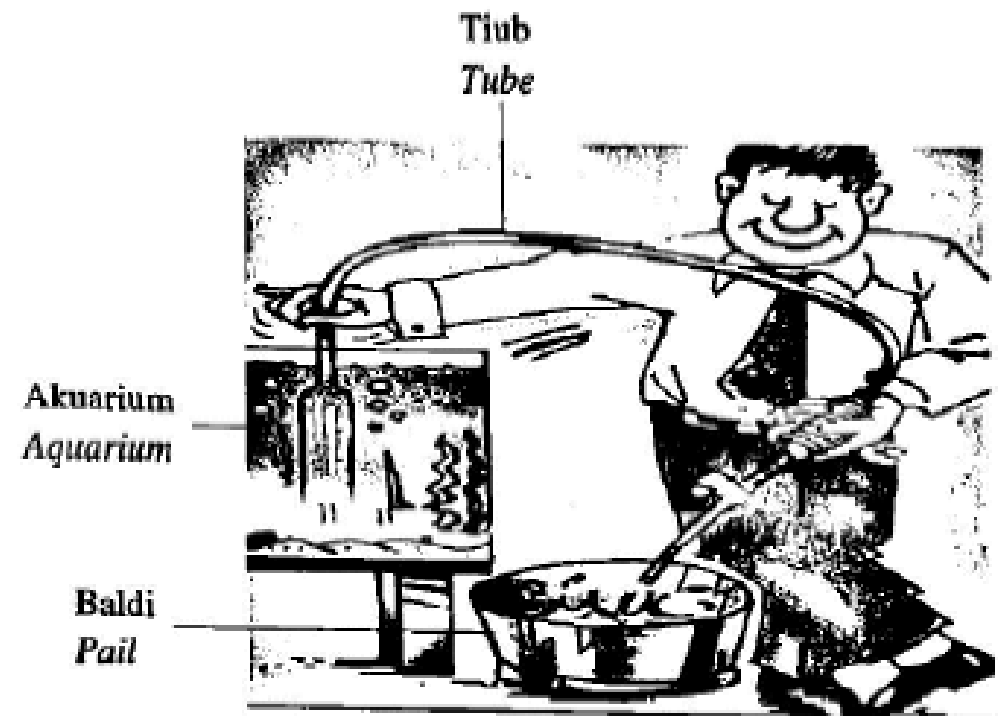

**Question 5**

Diagram 5 shows how water is supplied to a house from an outdoor storage tank. The water pipe in the house leaks at two points, P and Q.

Rajah 5 menunjukkan cara air dibekalkan ke sebuah rumah dari sebuah tangki simpanan di luar rumah. Paip air di dalam rumah bocor pada dua kedudukan, P dan Q.

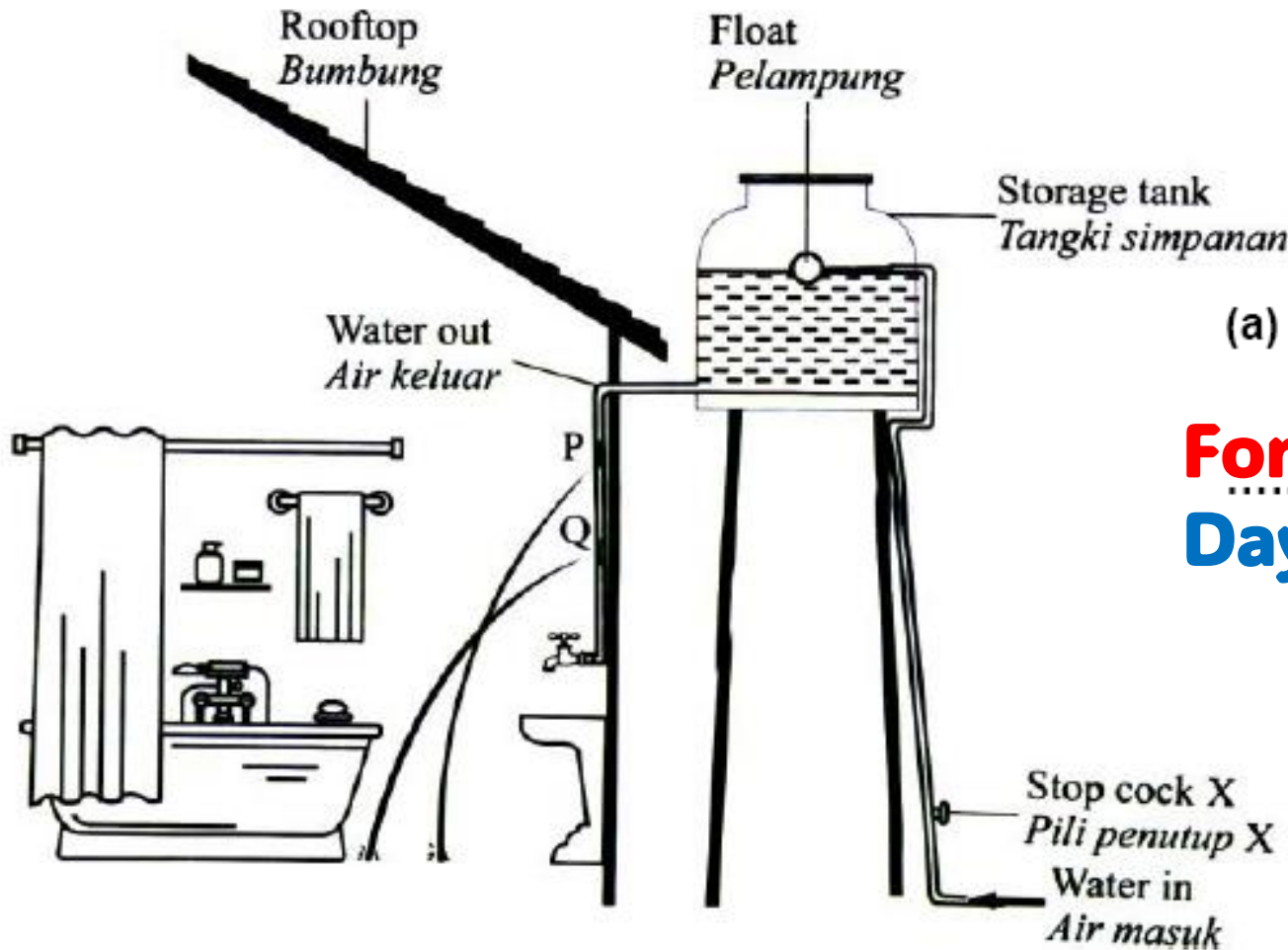

(a) What is the meaning of pressure?  
Apakah yang dimaksudkan dengan tekanan?

**Force per unit area**

**Daya per unit luas**

**Force/area**

**Daya/luas**

[1 mark]



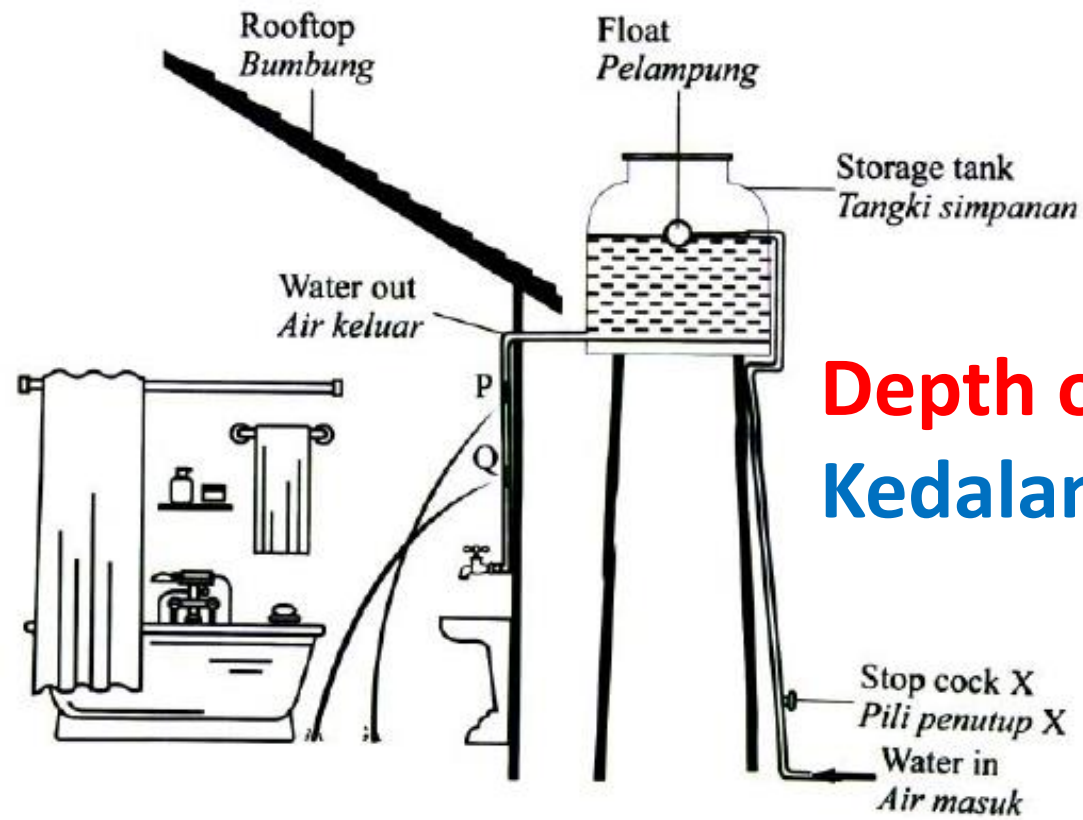

(b) Based on Diagram 5, compare  
*Berdasarkan Rajah 5, bandingkan,*

- (i) The depth of water at point P and point Q.  
*Kedalaman air pada kedudukan P dan kedudukan Q.*

**Depth of water at Q > depth of water at P**  
**Kedalaman air di Q > kedalaman air di P // Q > P**

- (ii) The horizontal distance of water spurting out from point P and point Q.  
*Jarak mengufuk pancutan air yang keluar dari kedudukan P dan kedudukan Q.*

**Q > P**

[1 mark]

- (iii) The pressure of water at point P and point Q  
*Tekanan air pada kedudukan P dan kedudukan Q.*

**Pressure of Q > Pressure of P**  
**Tekanan di Q > Tekanan di P / Q > P**



(c) Based on the answer in 5(b),  
*Berdasarkan jawapan dalam 5(b),*

- (i) Relate the pressure of water with the horizontal distance of water.  
*Hubungkan tekanan air dengan jarak mengufuk pancutan air.*

**Directly proportional / Berkadar terus**

[1 mark]

- (ii) State the relationship between the pressure and the depth of water.  
*Nyatakan hubungan antara tekanan dengan kedalaman air.*

**Directly proportional / Berkadar terus**

[1 mark]

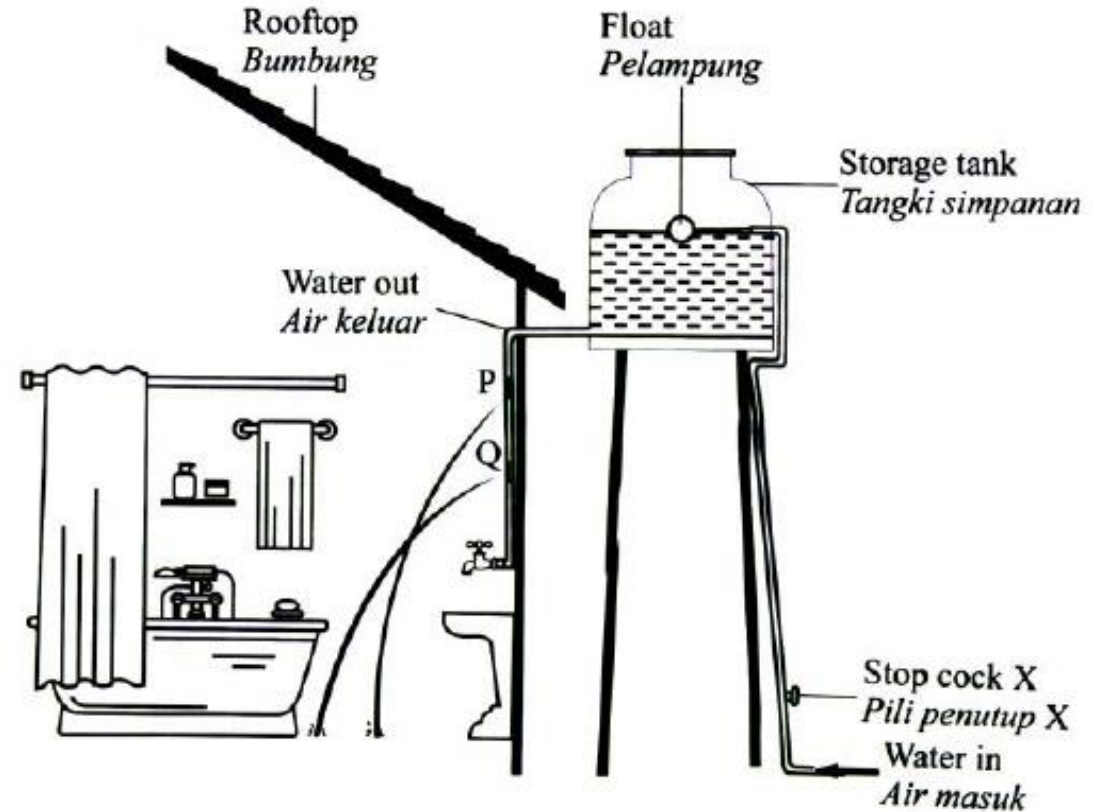

(d) To prevent wastage of water, stop cock X at the pipe that supplies water to the storage tank is turned off. What will happen to the distance of water spurting out from point Q? give one reason for your answer.

*Bagi mengelakkan pembaziran air, pili penutup X pada paip yang membekalkan air ke tangki simpanan ditutup. Apakah yang akan berlaku kepada jarak mengufuk pancutan air dari kedudukan Q? Berikan satu sebab bagi jawapan anda.*

**Decreases // Berkurang**

[2 marks]

**Depth decreases / pressure decreases  
kedalaman berkurang / Tekanan berkurang**

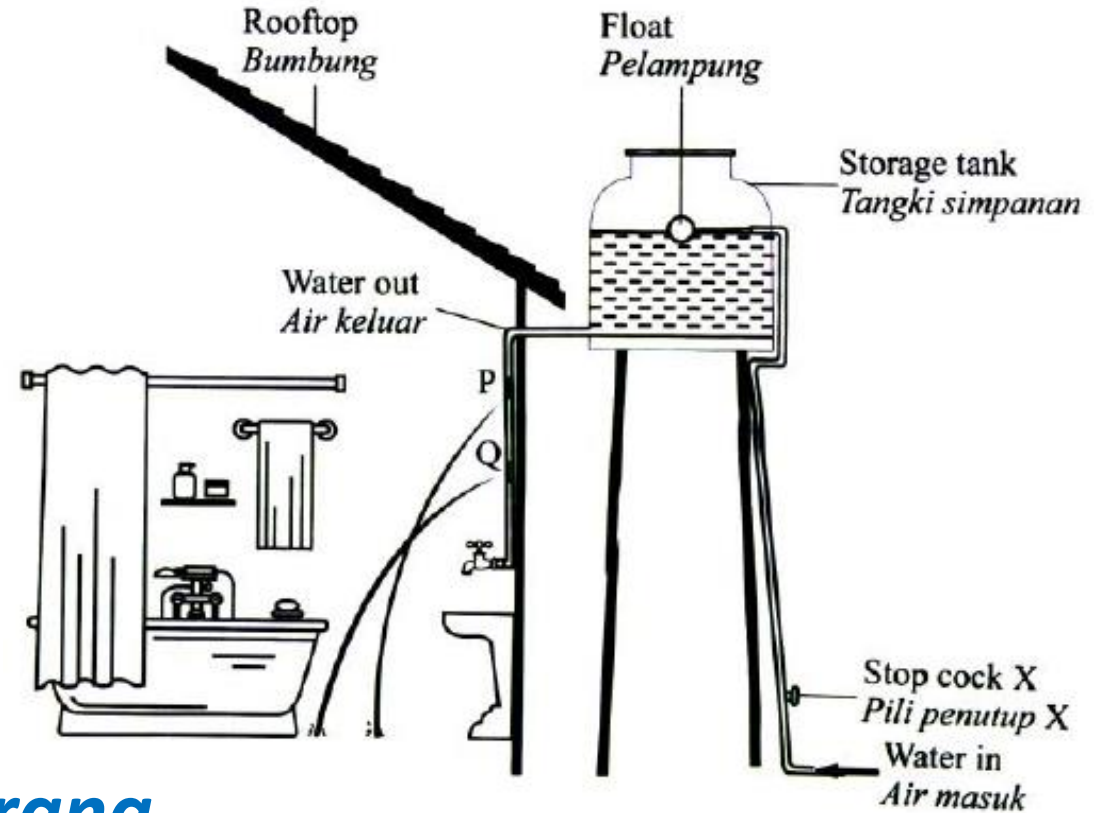

## Section A - 2014

### SPM 2014 Soalan 2

Rajah 2 menunjukkan satu alat yang digunakan untuk mengukur tekanan atmosfera.

Diagram 2 shows an instrument which is used to measure atmospheric pressure.

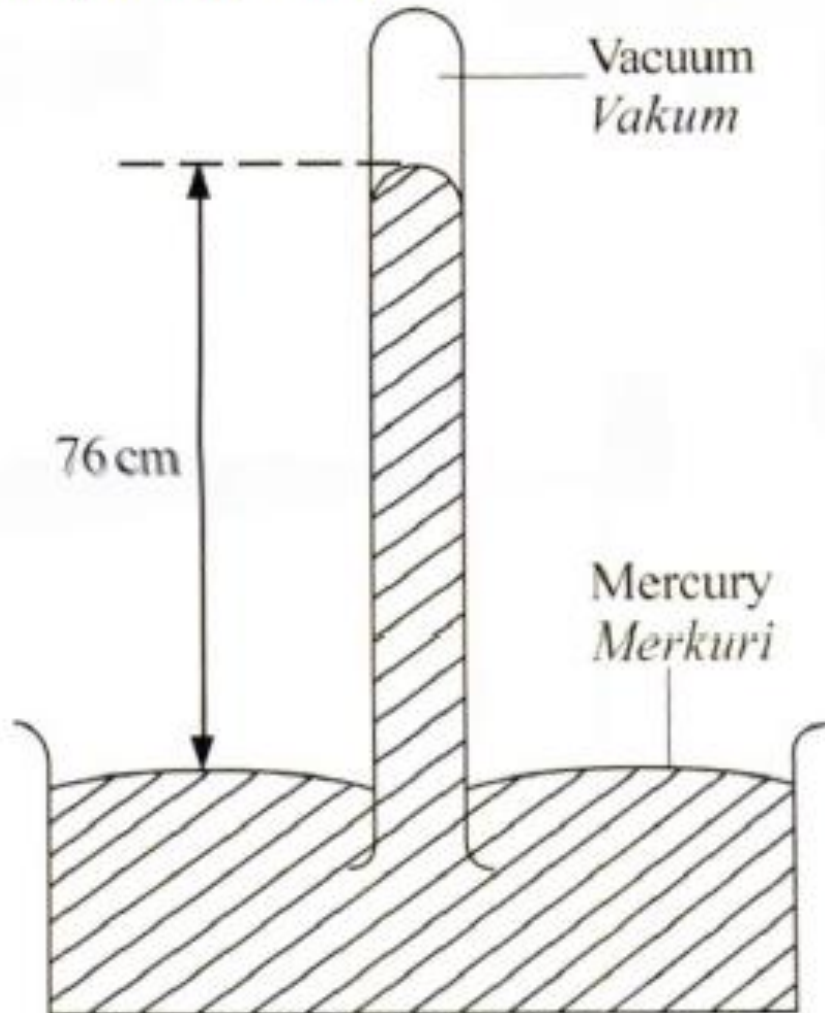

(a) Berdasarkan Rajah 2,  
Based on Diagram 2,

(i) Namakan alat yang digunakan untuk mengukur tekanan atmosfera

Name the instrument which is used to measure the atmospheric pressure.

**Barometer**

(i) Nyatakan satu sebab mengapa merkuri digunakan dalam alat tersebut.

State one reason why mercury is used in the instrument.

**Higher density // opaque // non stick**  
**Ketumpatan tinggi / legap / tidak melekat pada kaca**



(b) Berdasarkan Rajah 2,  
Based on Diagram 2,

(i) Nyatakan tekanan atmosfera dalam unit cm Hg.

*State the atmospheric pressure in the unit of cm Hg.*

**76 cm Hg**

---

(ii) hitung tekanan atmosfera dalam unit Pascal. [ketumpatan merkuri =  $13.6 \times 10^3 \text{ kg m}^{-3}$ ]

*Calculate the atmospheric pressure in the unit of Pascal.*

*[Density of mercury =  $13.6 \times 10^3 \text{ kg m}^{-3}$ ]*

$$\begin{aligned} P &= \rho gh \\ &= 13600 \times 10 \times 0.76 \\ &= 1.034 \times 10^5 \text{ Pa} \end{aligned}$$

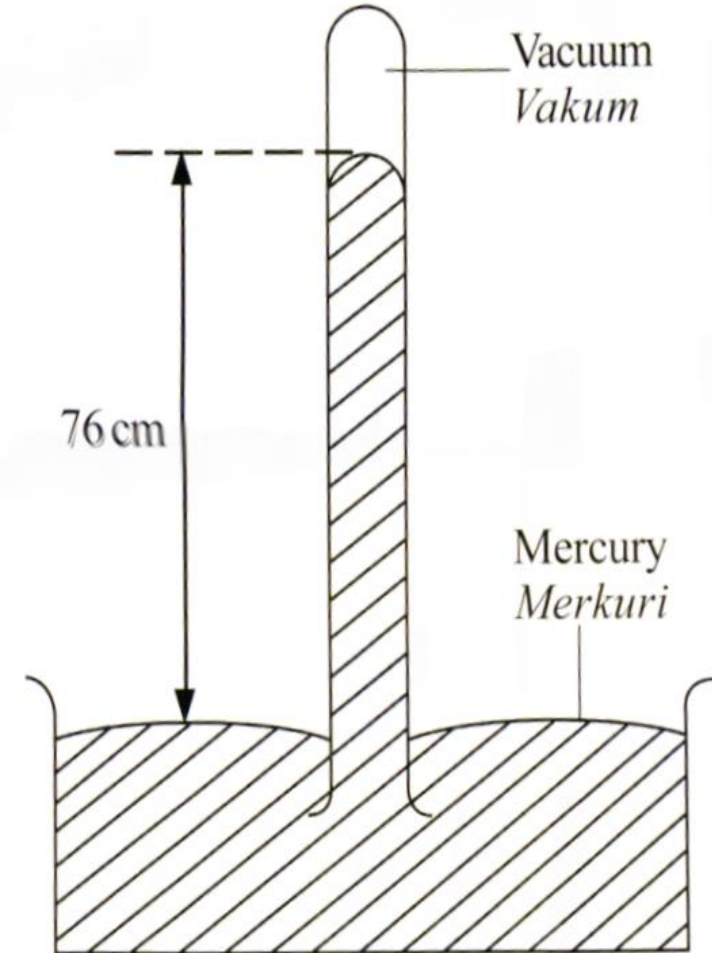

## Section A - 2008

7. Rajah 7.1 menunjukkan satu sistem hidraulik. Suatu daya  $F$  dikenakan ke atas omboh kecil.

*Diagram 7.1 shows a hydraulic system. A force  $F$  is exerted on the small piston.*

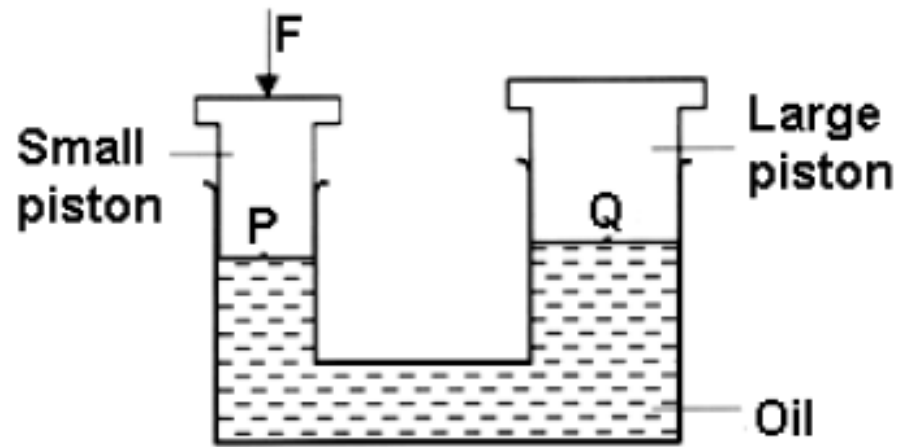

- (a) (i) Namakan prinsip yang terlibat dalam sistem hidraulik ini.  
*Name the principle involved in this hydraulic system.*

**Pascal' principle / Prinsip Pascal**

[1 mark]

- (ii) Bandingkan tekanan pada titik P dan pada titik Q.  
*Compare the pressure at point P and at point Q.*

$$P = Q$$

[1 mark]



- (b) Rajah 7.2 menunjukkan jek hidraulik di suatu pusat servis kereta.  
*Diagram 7.2 shows a hydraulic jack in a car service centre.*

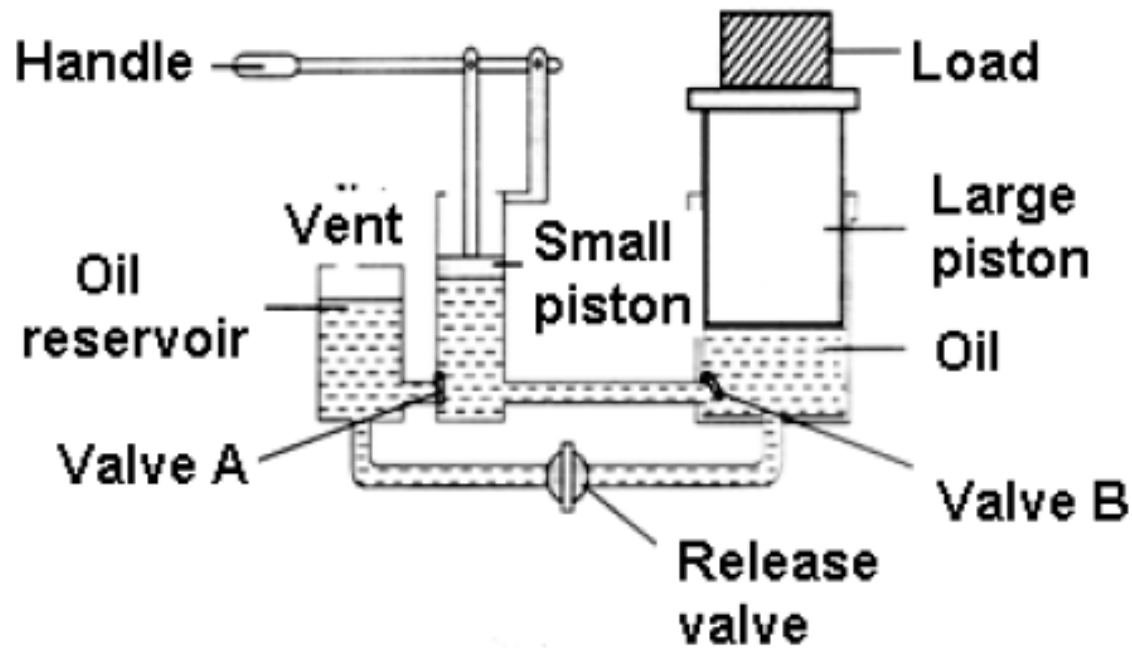

Satu daya 50 N bertindak ke atas omboh kecil apabila pemegang ditolak ke bawah. Luas keratan rentas omboh kecil dan omboh besar masing-masing adalah  $0.04 \text{ m}^2$  dan  $0.8 \text{ m}^2$ .

*A force of 50 N is exerted on the small piston when the handle is pushed down. The cross-sectional areas of the small piston and the large piston are  $0.04 \text{ m}^2$  and  $0.8 \text{ m}^2$  respectively.*

- (i) Hitung tekanan yang bertindak ke atas minyak dalam jek hidraulik itu.  
*Calculate the pressure exerted on the oil in the hydraulic jack.*

[2 marks]

$$\frac{50}{0.04} = 1250 \text{ Pa}$$

- (ii) Hitung daya dikenakan oleh minyak ke atas omboh besar itu?  
*Calculate the force that the oil exerts on the large piston.*

$$F = PA = 1250 \times 0.8 = 1000 \text{ N}$$

[1 mark]



- (c) Berdasarkan Rajah 7.2 / Based on Diagram 7.2,  
(i) Terangkan bagaimana pemegang digunakan untuk mengangkat beban itu pada ketinggian maksimum  
*explain how the handle is used to lift the load to its maximum height.*

**Push the handle down. Valve A closes valve B opens.**

**Tolak pemegang ke bawah. Injap A buka injap B tutup**

.....

.....

[2 marks]

**This will transmit pressure and allow oil move to the large piston.**  
**Tekanan dipindahkan dan minyak pindah ke piston besar.**



- (ii) Terangkan satu pengubahsuaian kepada omboh besar untuk membolehkan jek itu mengangkat beban yang lebih berat.  
*explain one modification to the large piston that enables the jack to lift a heavier load,*

**Increases the area of large piston**  
**This will increase the output force**  
**Tambah luas piston besar** [2 marks]  
**Daya output besar**

- (iii) Bagaimanakah pemberat diturunkan?  
*How does the load is lowered?*

**Open the release valve**  
**Buka injap pelepas** [1 mark]



## Section A - 2013

Diagram 2 shows a log floats at the surface of river water.

Rajah 2 menunjukkan satu kayu balak terapung pada permukaan air sungai.

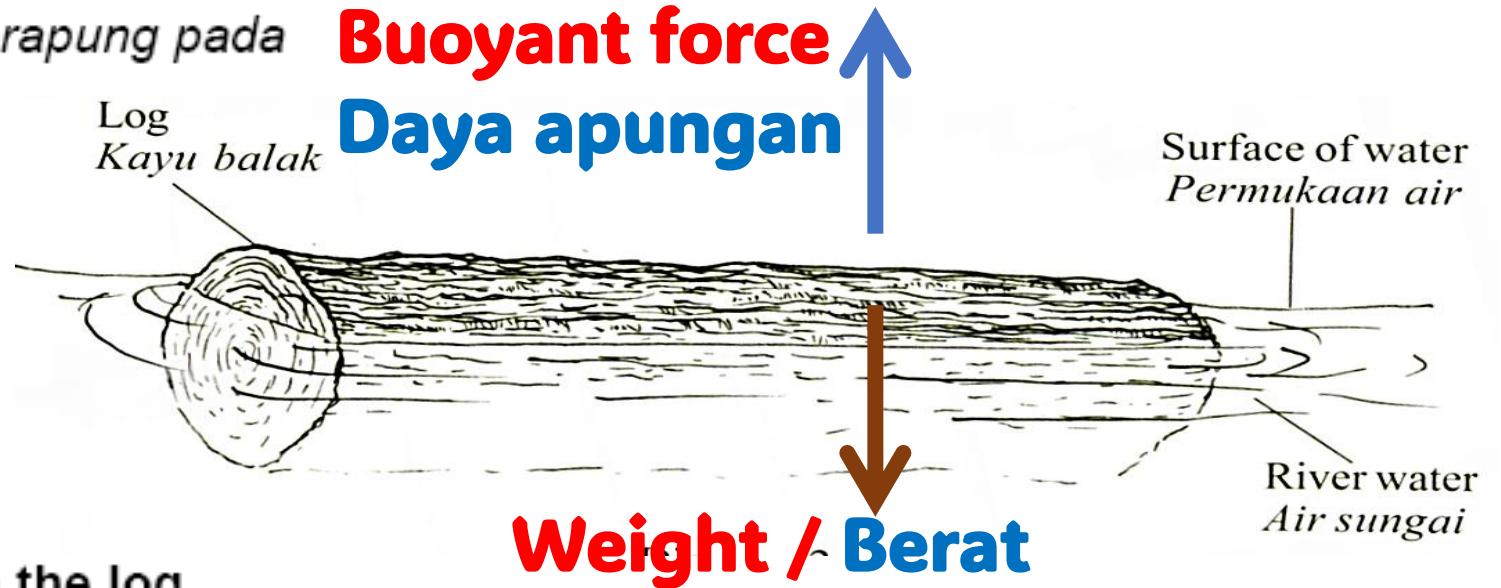

- (a) Name one force that is acting on the log.  
*Namakan satu daya yang bertindak ke atas kayu balak.*

**Buoyant force / Weight**  
**/ daya apungan / Berat**

[1 mark]

- (b) Give one reason why the log floats.  
*Beri satu sebab mengapa kayu balak terapung.*

**Buoyant force = Weight of the log**  
**Daya apungan = berat kayu balak**

[1 mark]



- (c) The mass of the log is 1 200 kg and the density of river water is 1 000 kg m<sup>-3</sup>. Calculate the volume of water displaced by the log.

*Jisim kayu balak ialah 1 200 kg dan ketumpatan air sungai ialah 1 000 kgm<sup>-3</sup>. Hitung isipadu air yang disesarkan oleh kayu balak.*

[2 marks]

**Buoyant force = Weight**

$$\rho V g = mg$$

$$1000 \times V \times 10 = 1200 \times 10$$

$$V = 12000/10000 \\ = 1.2 \text{ m}^3$$

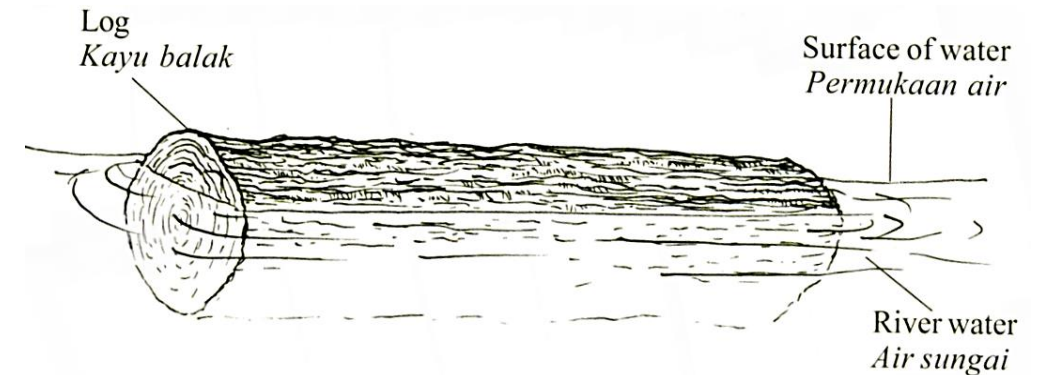

- (d) What happens to the volume of water displaced when the log floats in sea water?

*Apakah yang berlaku pada isipadu air yang disesarkan apabila kayu balak terapung dalam air laut?*

**Decrease / berkurang**

[1 mark]



## Section A - 2009

### Question 5

Rajah 5.1 dan Rajah 5.2 menunjukkan sebuah neraca spring menyokong satu blok logam dalam dua situasi. Blok-blok logam itu adalah serupa. Neraca mampatan pada Rajah 5.1 dan Rajah 5.2 masing-masing menunjukkan bacaan berat sebuah bikar kosong dan berat sebuah bikar berisi air. Bikar-bikar itu adalah serupa.

*Diagram 5.1 and Diagram 5.2 show a spring balance supporting a metal block in two situations. The metal blocks are identical.*

*The compression balance in Diagram 5.1 and in Diagram 5.2 show the readings of the weight of an empty beaker and the weight of a beaker filled with water respectively. The beakes are identical.*

- (a) Apakah maksud berat  
*What is the meaning of weight?*

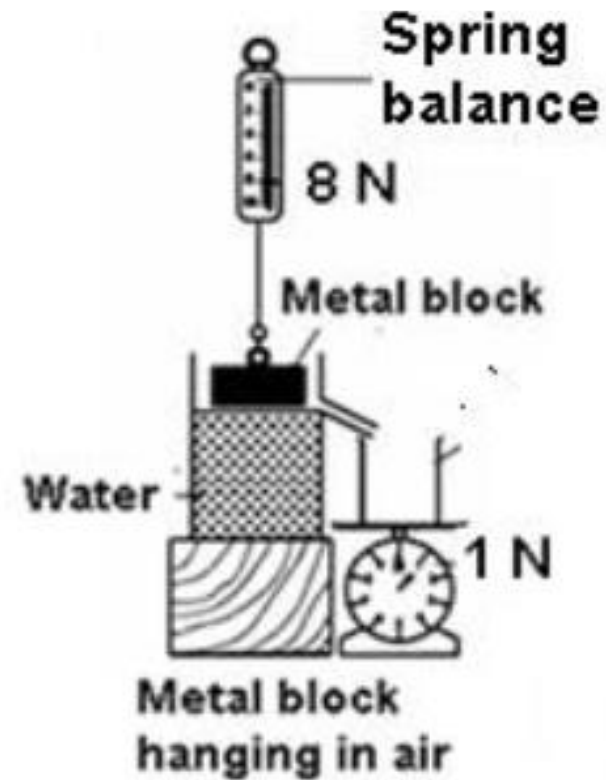

Diagram 5.1

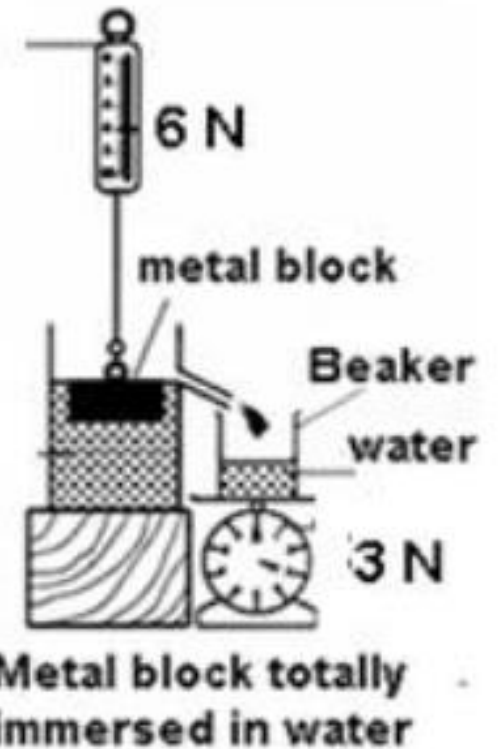

Diagram 5.2

**Gravitational force acts on an object**

**Daya tarikan gravity yang bertindak ke atas objek**



(b) (i) Apakah beza antara bacaan neraca spring di Rajah 5.1 dengan Rajah 5.2?  
*What is the difference between the spring balance reading in Diagram 5.1 and Diagram 5.2?*

.....**2 N**.....N [1 m]

(ii) Namakan daya yang diwakili oleh bacaan di 5(b)(i).  
*Name the force that is represented by the reading in 5(b)(i).*

.....**Buoyant force / Daya apungan**.....  
 [1 m]

(c)(i) Berapakah bacaan neraca mampatan di Rajah 5.2?  
*What is the reading of the compression balance in Diagram 5.2?*

.....**2 N**.....  
 [1 m]

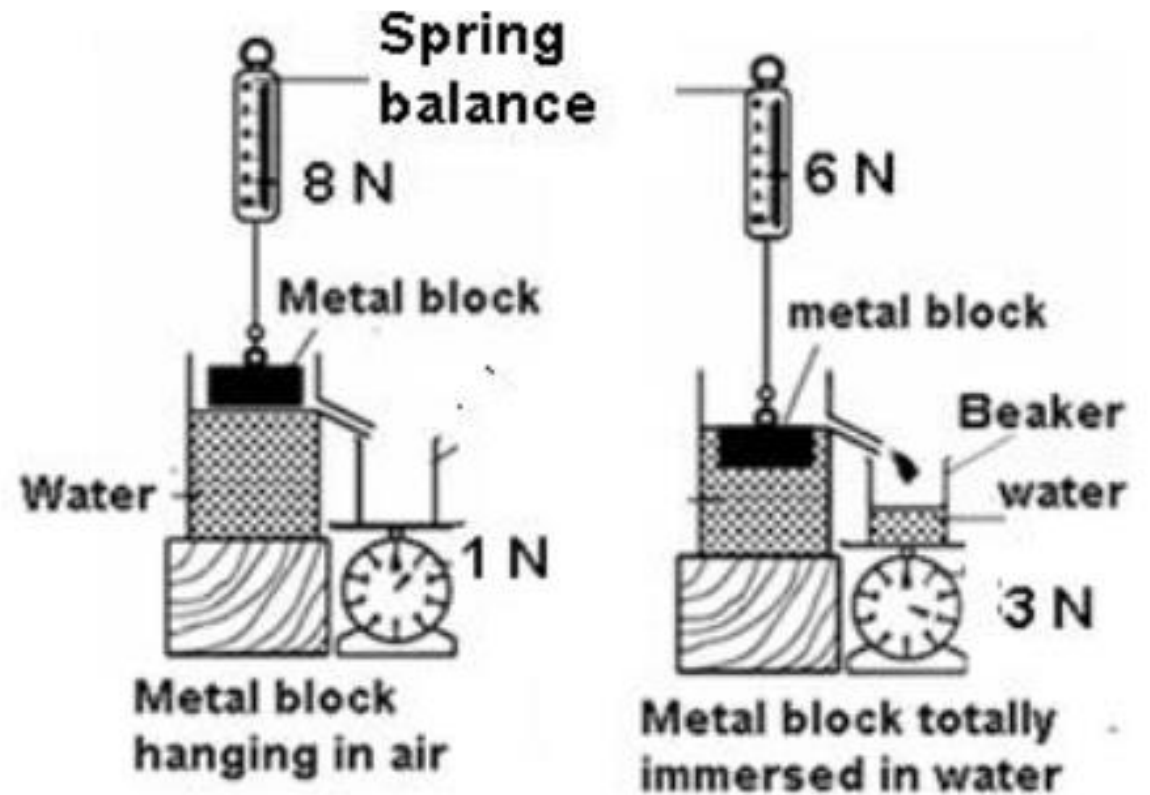

Diagram 5.1

Diagram 5.2

(ii) Namakan kuantiti fizik yang mewakili oleh bacaan di 5(c)(i).  
*Name the physical quantity that is represented by the reading in 5(c)(i)*

.....**Weight of water displaced**.....  
 .....**berat air yang disesarkan**..... [1 m]

(d)(i) Hubungkan jawapan di 5(b)(ii) dengan 5(c)(ii).

*Relate the answers in 5(b)(ii) and 5(c)(ii).*

**Weight of water displaced = buoyant force**  
**berat air yang disesarkan = daya apungan**

(ii) Namakan prinsip fizik yang terlibat dalam situasi ini.

*Name the physics principle involved in these situations.*

**Archimedes' principle**  
**Prinsip Archimedes**

[1 m]

(e) Apakah yang terjadi kepada bacaan neraca spring di Rajah 5.2 apabila blok logam direndam lebih dalam ke dalam air?

*What happens to the spring balance reading in Diagram 5.2 when the metal block is immersed deeper into the water?*

**Unchanged / tidak berubah**

[1 m]



## Section A - 2003

5. Figure(a), Figure(b) and Figure(c) show a spring balance supporting a metal block K in three situations.

*Rajah (a), Rajah (b) dan Rajah (c) menunjukkan satu neraca spring menampung satu bongkah logam K dalam tiga keadaan.*

- (a) Compare the readings of the spring balance in Figure(a) and Figure(b)

*Bandingkan bacaan neraca spring itu dalam Rajah (a) dan Rajah (b)*

**Figure (a) > figure (b)**

[1 m]



K hanging in the air

(a)

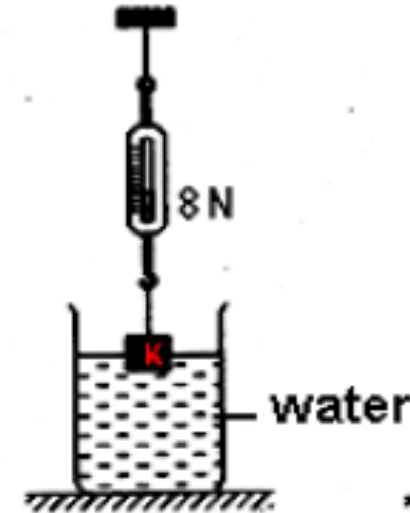

K partially in water

(b)

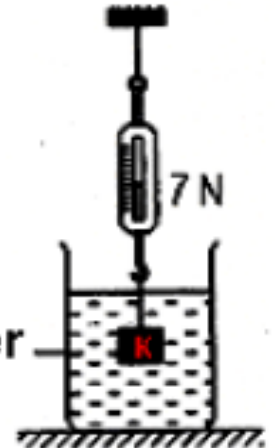

K totally in water

(c)



(b) Name three forces that act on K when it partially or totally in water.

*Namakan tiga daya yang bertindak pada K semasa terendam sebahagian atau sepenuhnya dalam air.*

**Daya apungan, tegangan tali, berat**  
**Buoyant force, tension, weight**

[2 m]

(c) State and explain the relationship between the forces in (b).

*Nyata dan terangkan hubungan antara daya-daya di (b).*

**Daya apungan + tegangan = Berat.**  
**Keseimbangan daya**

**Buoyant force + tension = Weight**  
**Equilibrium of forces**



K hanging in the air

(a)

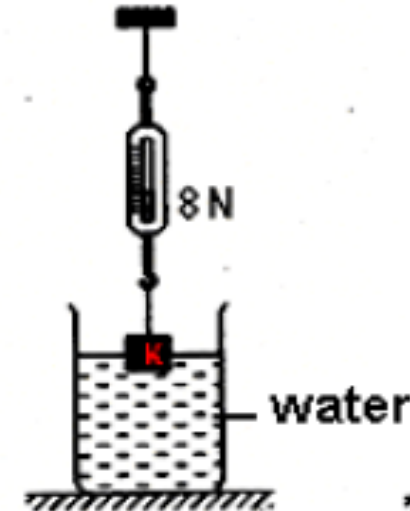

K partially in water

(b)

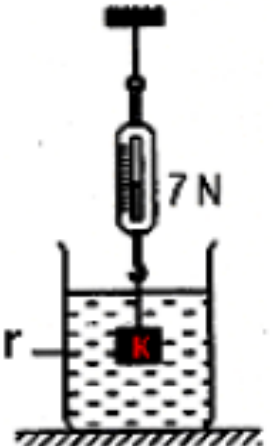

K totally in water

(c)



(d) Name the principle involved in (c)

*Namakan prinsip yang terlibat di (c).*

## **Prinsip Archimedes / Archimedes principle**

[1 m]

(e)(i) What will happen to the reading of the spring balance in Figure (c) if the water is replaced with salt solution?

*Apakah yang berlaku kepada bacaan neraca spring pada Rajah (c) jika air itu digantikan dengan larutan garam?*

## **Berkurang / Decrease**

[1 mark]

(ii) Give one reason for your answer.

*Berikan satu sebab bagi jawapan anda.*

**Daya apungan bertambah kerana air garam lebih tumpat**

[1 m]

**Buoyant force increases because salt solution is denser.**



## Section A - 2019

3. Diagram 3 shows a submarine floating stationary on the surface of the sea.  
*Rajah 3 menunjukkan sebuah kapal selam yang terapung pegun di permukaan laut.*

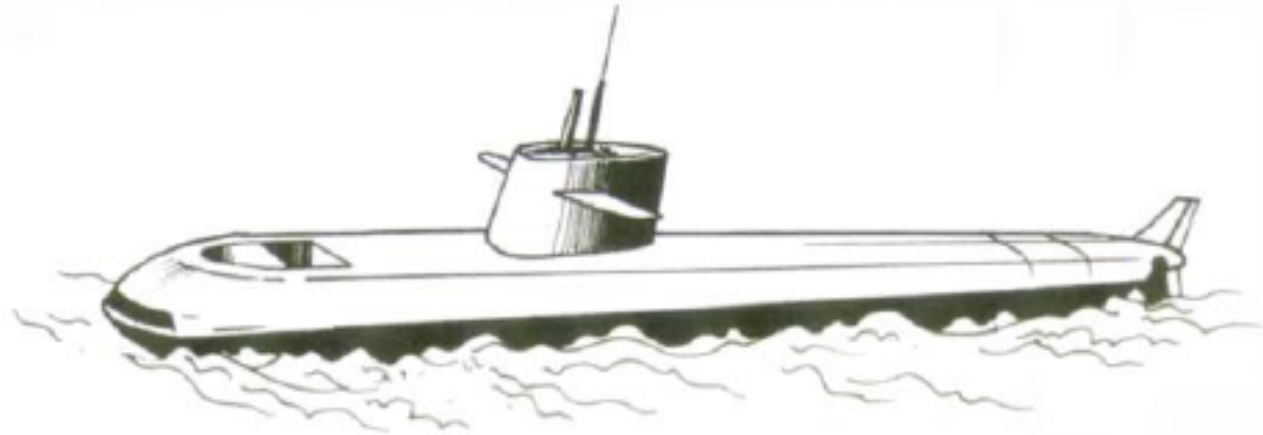

Diagram 3 / Rajah 3

- (a) State the principle that enable the submarine to float.

*Nyatakan prinsip yang membolehkan kapal selam itu terapung.*

**Archimedes principle / equilibrium of forces**

**Prinsip Archimedes / keseimbangan daya**



- (b) The mass of the submarine is  $1.5 \times 10^7$  kg  
*Jisim kapal selam tersebut ialah  $1.5 \times 10^7$  kg.*  
[Density of sea water =  $1.03 \times 10^3$  kg m<sup>-3</sup>]  
[Ketumpatan air laut =  $1.03 \times 10^3$  kg m<sup>-3</sup>]

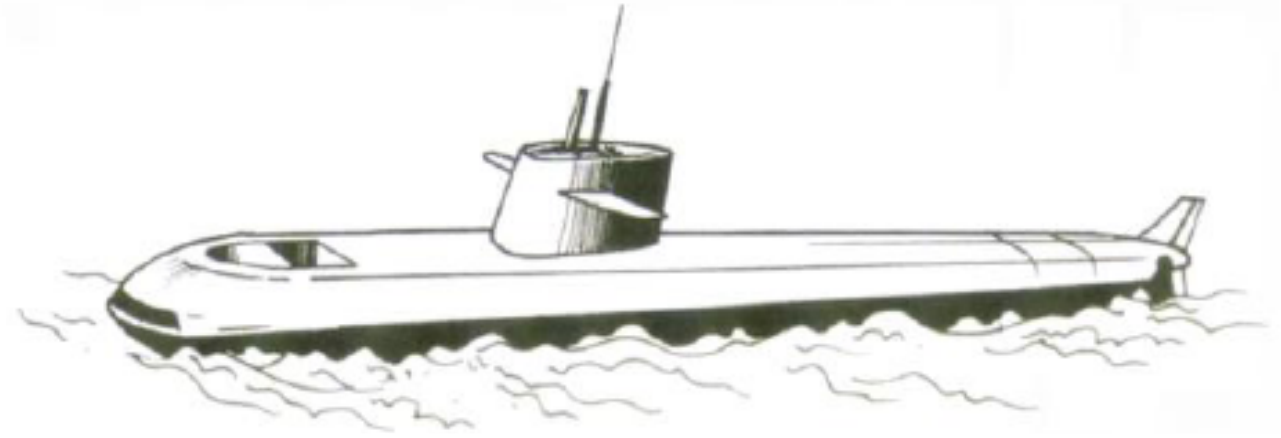

Calculate / *Hitung*;

- (i) the buoyant force acted on the submarine.  
*Daya apungan yang bertindak ke atas kapal selam.*

[2 marks]

$$\text{M1: } (1.5 \times 10^7) (10) / F = W = mg / F = \rho Vg$$

$$\text{M2: } 1.5 \times 10^8 \text{ N}$$

- (ii) the volume of the sea water displaced.  
*Isipadu air laut yang tersesar.*

[2 marks]

$$F = \rho Vg$$

$$(1.5 \times 10^8) = (1.03 \times 10^3)(V)(10)$$

$$\frac{1.5 \times 10^7}{1.03 \times 10^3}$$

$$V = 1.456 \times 10^4 \text{ m}^3$$



(c) When water is filled into the ballast tank, the submarine submerges into the sea. Give one reason why the submarine submerged.

*Apabila air diisi ke dalam tangki balast, kapal selam tersebut tenggelam ke dalam laut. Beri satu sebab mengapa kapal selam itu tenggelam.*

**Weight > Bouyant Force**

**Berat > daya Apungan**

[1 mar

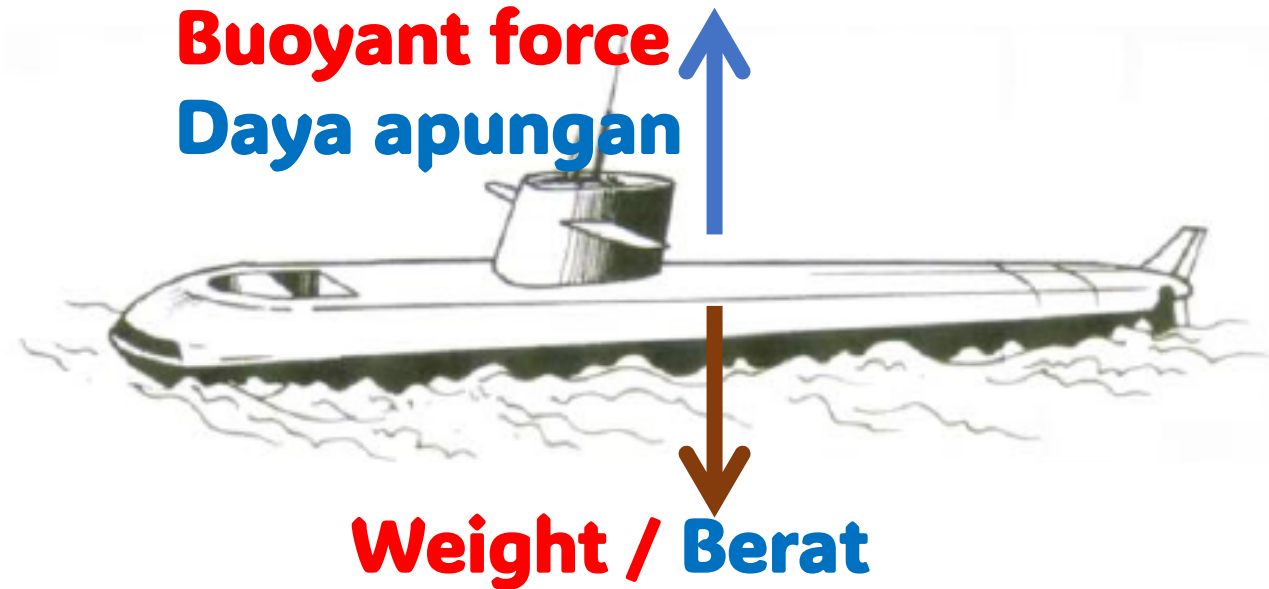

## Section A - 2022

- 6 Rajah 6 menunjukkan dua orang atlet sedang mendayung kayak P dan kayak Q yang serupa dengan berat yang sama iaitu 300 N. Kedua-dua kayak tersebut terapung di air sungai. Berat atlet X dan atlet Y masing-masing adalah 800 N dan 500 N.

*Diagram 6 shows two athletes are rowing kayak P and Q which are identical with the same weight of 300 N. Both kayaks are floating in the river water. The weights of athlete X and athlete Y are 800 N and 500 N respectively.*

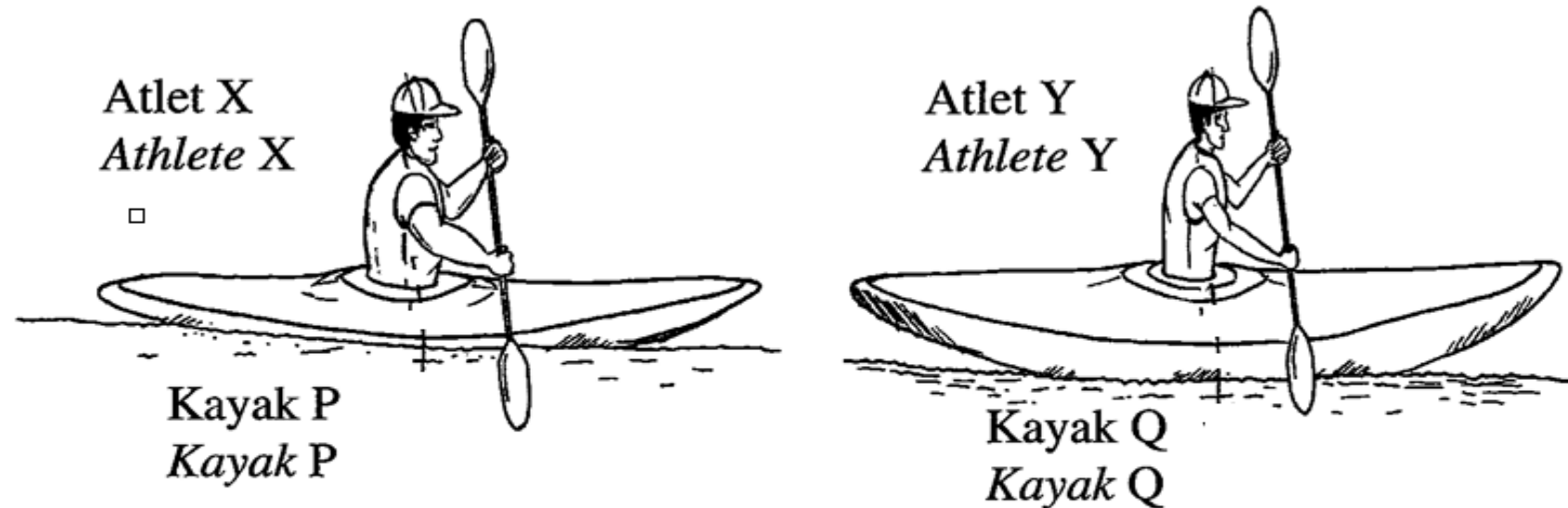

Rajah 6  
Diagram 6



(a) Apakah maksud berat?

*What is the meaning of weight?*

✓ **Daya graviti yang bertindak ke atas objek**

✓ **Gravitational force acting on an object**

✓ **Jisim x kekuatan medan graviti**

✓ **Mass x gravitational field strength**

[1 markah]

[1 mark]



- (b) (i) Menggunakan konsep daya, nyatakan bagaimana kayak-kayak tersebut boleh terapung di permukaan air.

*Using the concept of force, state how the kayaks can float on the water surface.*

.....

**Daya apungan = jumlah berat objek**

[1 markah]

✓ **Buoyant force = total weight of object**

[1 mark]

✓ **Daya apungan = berat / Buoyant force = weight**

✓ **Daya apungan = berat kayak + berat atlet**

✓ **Buoyant force = weight of kayak + weight of athlete**



(ii) Kayak P telah menyesarkan sejumlah isipadu air sungai semasa terapung.

Hitung isipadu air sungai yang disesarkan,  $V$ .

[ ketumpatan air sungai,  $\rho = 1000 \text{ kg m}^{-3}$  ]

*Kayak P has displaced a certain volume of river water while floating.*

*Calculate the volume of river water displaced,  $V$ .*

*[ density of river water,  $\rho = 1000 \text{ kg m}^{-3}$  ]*

$$F_B = \rho Vg / W = \rho Vg / F = \rho Vg / mg = \rho Vg$$
$$\checkmark 1100 = 1000 \times V \times 9.81$$

$$V = \dots 0.112 / 0.1121 \dots \text{m}^3 \quad (\text{min 3 tp})$$

[2 markah]

[2 marks]

**Reject: 0.11**





(c) Berdasarkan Rajah 6,  
*Based on Diagram 6,*

- (i) Kayak manakah menampung berat beban yang lebih besar?  
*Which kayak accomodate a larger load?*

**M1: P / P > Q**

---

[1 *markah*]

[1 *mark*]



(ii) Kayak manakah yang menyesarkan lebih banyak isipadu air sungai?

*Which kayak displaces more volume of river water?*

**P / P > Q**

---

[1 markah]

[1 mark]

(iii) Kayak manakah yang mempunyai daya apungan yang lebih besar?

*Which kayak has greater buoyant force?*

**P / P > Q**

---



[1 markah]

[1 mark]

(d) Menggunakan jawapan anda di 6(c), hubungkan,  
*Using your answer in 6(c), relate,*

(i) berat beban dengan isi padu air yang tersesar.

*the weight of the load and the volume of water displaced.*

**Berat beban bertambah, isipadu air tersesar bertambah**

✓ **Weight of load increases, the volume of water displaced increases** [1 markah]  
**/ berkadar terus / directly proportional /  $W \propto V$**  [1 mark]

(ii) berat beban dengan daya apungan.

*the weight of the load and the buoyant force.*

**Berat beban bertambah, daya apungan bertambah**

**Weight of load increases, buoyant force increases**

✓ **berkadar terus / directly proportional /  $W \propto F$**



[1 markah]

[1 mark]

## Section A - 2020

2. Rajah 2 menunjukkan aliran udara yang mengalir menentang sebiji bola ping pong yang berputar setelah dipukul oleh seorang pemain ping pong. Diagram 2 shows the streamlines of air that flow against a spinning ping pong ball after being hit by a table tennis player.

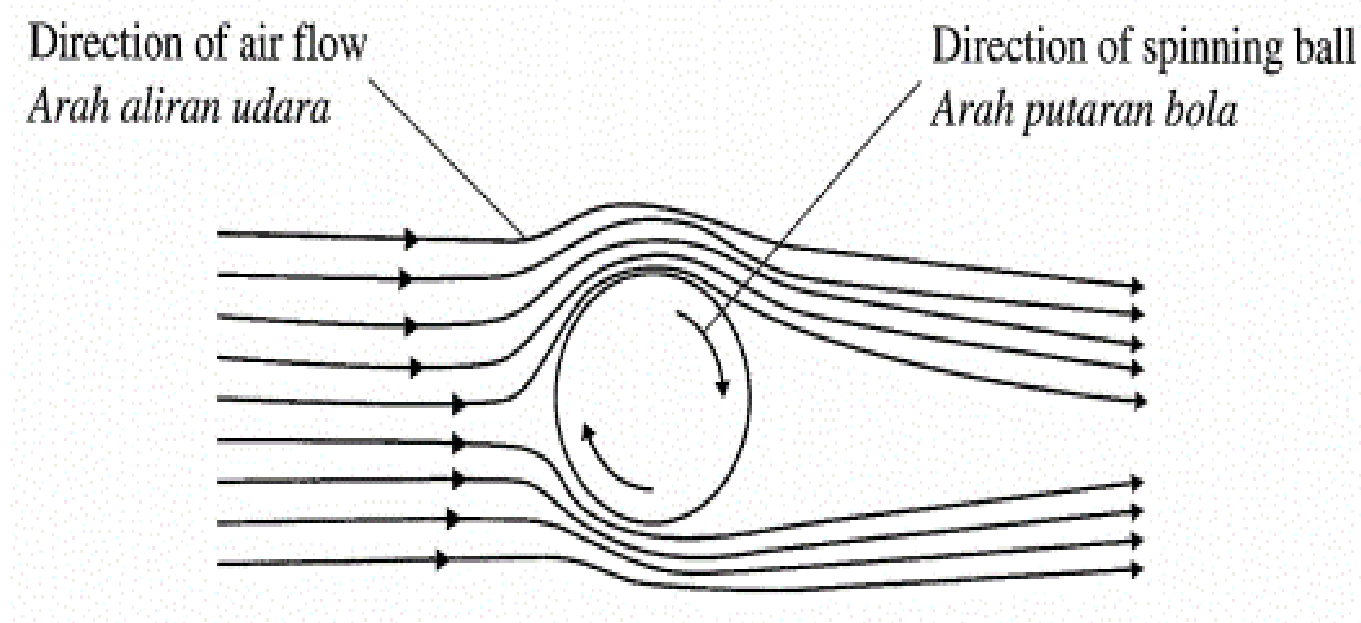

(a) Dalam Rajah 2/ In Diagram 2,  
(i) tandakan X pada kawasan aliran udara yang mengalir pada kelajuan yang lebih tinggi.

mark X at the region where the streamlines of air that flow at a higher speed.

[1 m]

(ii) tandakan Y pada kawasan aliran udara yang mengalir pada tekanan yang lebih tinggi.

mark Y at the region where the streamlines of air that flow at a higher pressure.

[1 m]

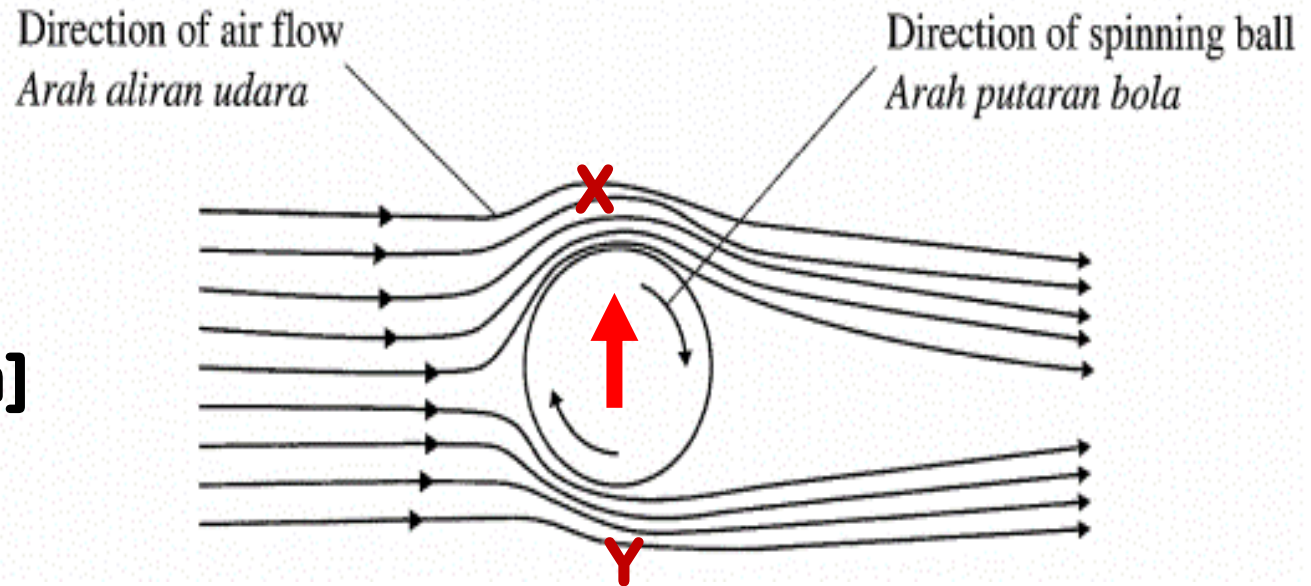

(iii) lukis anak panah untuk menunjukkan arah daya paduan, F yang bertindak ke atas bola ping pong.

draw an arrow to show the direction of the resultant force, F that acted on the ping pong ball.

[1 m]

(iv)nyatakan satu sebab mengapa aliran udara yang mengalir pada kelajuan yang di X lebih tinggi?

state one reason why the streamlines of air that flow at X is at a higher speed?  
[1 m]

**Bola dan aliran udara mempunyai arah yang sama**  
**The ball and air flow have the same direction**

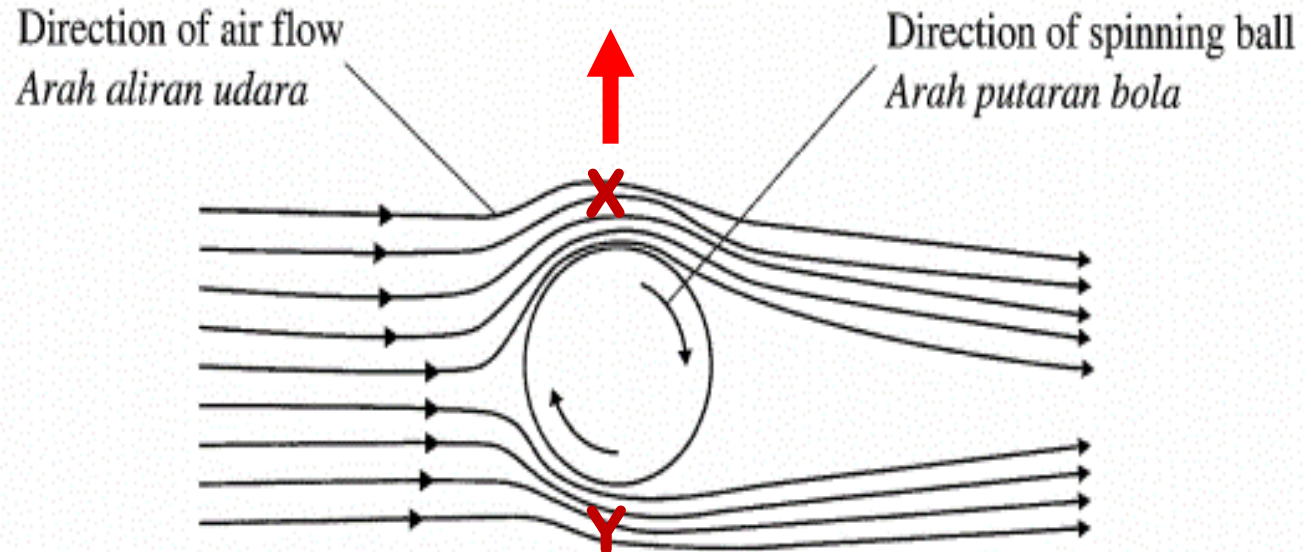

(b) Namakan prinsip fizik yang terlibat dalam (a)(iii).  
Name the principle of physics that is involved in 2(a)(iii).

**Prinsip Bernoulli**  
**Bernoulli's principle**

[1 m]



## Section A - 2005

### Question 5

Figure(a) shows a piece of paper hanging from a retort stand. When air flows from the nozzle of an air pump, the paper changes its position as shown in Figure(b).

Rajah (a) menunjukkan sekeping kertas digantung pada satu kaki retort. Apabila udara dialirkan dari muncung suatu pam udara, kedudukan kertas itu berubah seperti ditunjukkan pada Rajah (b)



Figure(a)

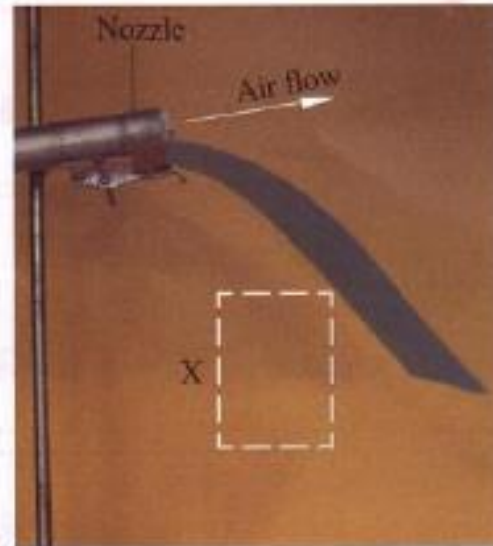

Figure(b)

- (a) Compare the position of paper in Figure(a) and Figure(b)  
Bandingkan kedudukan kertas itu dalam Rajah (a) dan Rajah (b).

**Rajah (b) di tolak ke atas**

**Diagram (b) is pushed upward**



(b) **F** is a force that causes the paper to change its position. In box, X, on Figure(b) , indicate and label the direction of **F** that acts on the paper.

*F ialah daya yang menyebabkan kedudukan kertas itu berubah. Dalam petak bertanda X, pada Rajah (b), tanda dan labelkan arah F yang bertindak ke atas kertas itu.*

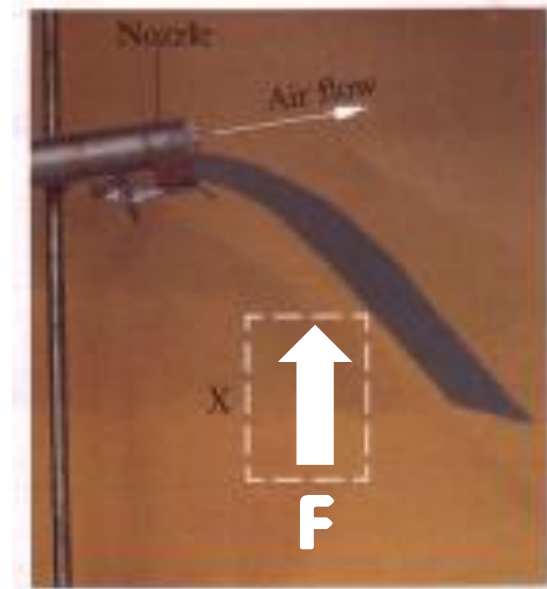

(c) Explain how **F** is produced?

*Terangkan bagaimana F dihasilkan.*

**Udara bergerak laju di atas, tekanan rendah**

**Air flows at high speed above, so the pressure is lower**

**Daya bertindak dari Kawasan tekanan tinggi ke tekanan rendah / perbezaan tekanan hasilkan daya**

**Forces acts from higher pressure to lower pressure area / difference in pressure produces force.**



- (d) (i) Compared to the position of the paper in Figure(b), how does the position of the paper change when the air flows faster?

*Berbanding dengan kedudukan kertas itu pada Rajah (b), apakah perubahan pada kedudukan kertas itu jika udara mengalir lebih laju?*

**Lebih tinggi / lifts up further**

[1 mark]

- (ii) Give reason to your answer in d(i).

*Berikan sebab bagi jawapan anda di (d)(i).*

**Tekanan semakin rendah bila udara bergerak lebih laju / daya yang dihasilkan bertambah**

**Pressure is lower when the air flows faster / force increases**

[1 m]

- (e) Name the principle that causes the observations in Figure (b).

*Namakan prinsip yang menyebabkan pemerhatian pada Rajah (b).*

**Prinsip Bernoulli / Bernoulli's principle**

[1 m]

- (f) Name one piece of apparatus in a school laboratory which uses the principle in(e).

*Namakan satu alat yang terdapat di dalam makmal sekolah yang menggunakan prinsip di (e).*

**Penunu Bunsen / Bunsen burner**

[1 m]



## Section A - 2017

### Question 2

Diagram 2 shows a cross-section of a spoiler which is attached to a racing car. The aerofoil shape of the spoiler produces a downward force when air flows through it.

*Rajah 2 menunjukkan keratan rentas sebuah spoiler yang dipasang kepada sebuah kereta lumba. Bentuk aerofoil bagi spoiler tersebut menghasilkan satu daya ke bawah apabila udara mengalir melaluinya.*

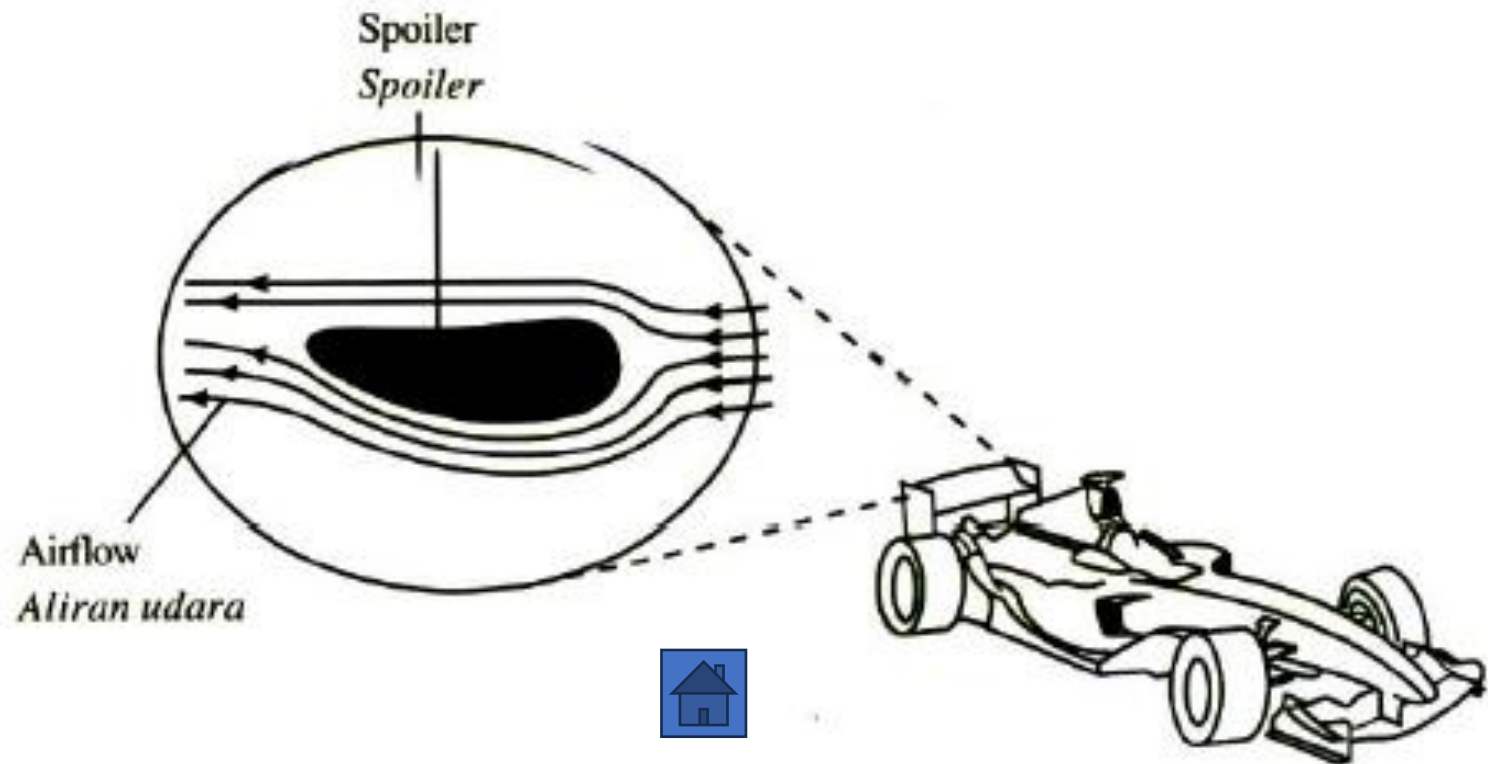

(a) Name the principle involved in producing the downward force.

*Namakan prinsip yang terlibat untuk menghasilkan daya ke bawah.*

**Bernoulli's principle /  
prinsip Bernoulli**

[1 mark]

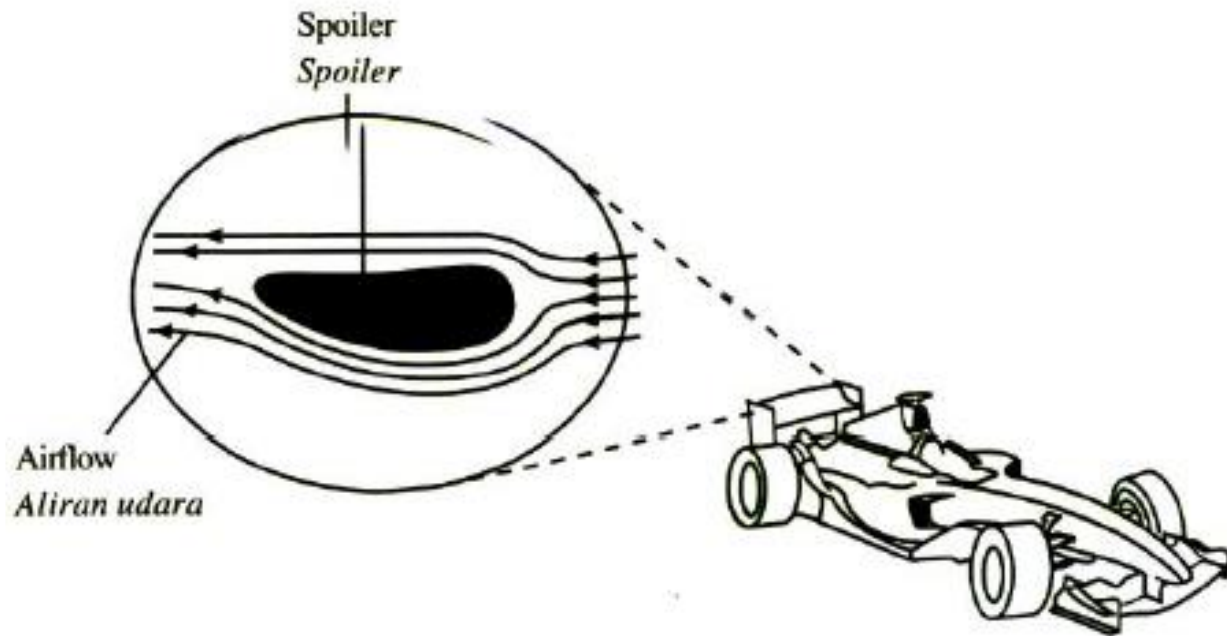

$$F = PA = (1000)(0.25) = 250 \text{ N}$$

(b) The area of the upper surface of the spoiler is  $0.25 \text{ m}^2$ . The pressure at the upper surface of the spoiler is  $1500 \text{ Pa}$  and the pressure at the lower surface is  $500 \text{ Pa}$ .

*Luas permukaan atas spoiler adalah  $0.25 \text{ m}^2$ . Tekanan pada permukaan atas spoiler tersebut adalah  $1500 \text{ Pa}$  dan tekanan pada permukaan bawahnya adalah  $500 \text{ Pa}$ .*

Calculate / Hitung

(i) the difference in pressure between the upper and lower surfaces of the spoiler.

*perbezaan tekanan antara permukaan atas dan bawah bagi spoiler tersebut.*

[1 mark]

$$1500 - 500 = 1000 \text{ Pa}$$

(ii) the downward force acting on the spoiler due to the difference in pressure in 2(b)(i).

*daya ke bawah yang bertindak ke atas spoiler tersebut disebabkan perbezaan tekanan dalam 2(b)(i).*

[2 marks]



(c) Give one reason why a downward force is needed when the racing car is moving fast.

*Beri satu sebab mengapa daya ke bawah diperlukan apabila kereta lumba itu bergerak dengan laju.*

**Prevent lift / stay on ground/ stabil /** .....  
**elak terangkat ke atas** [1 mark]

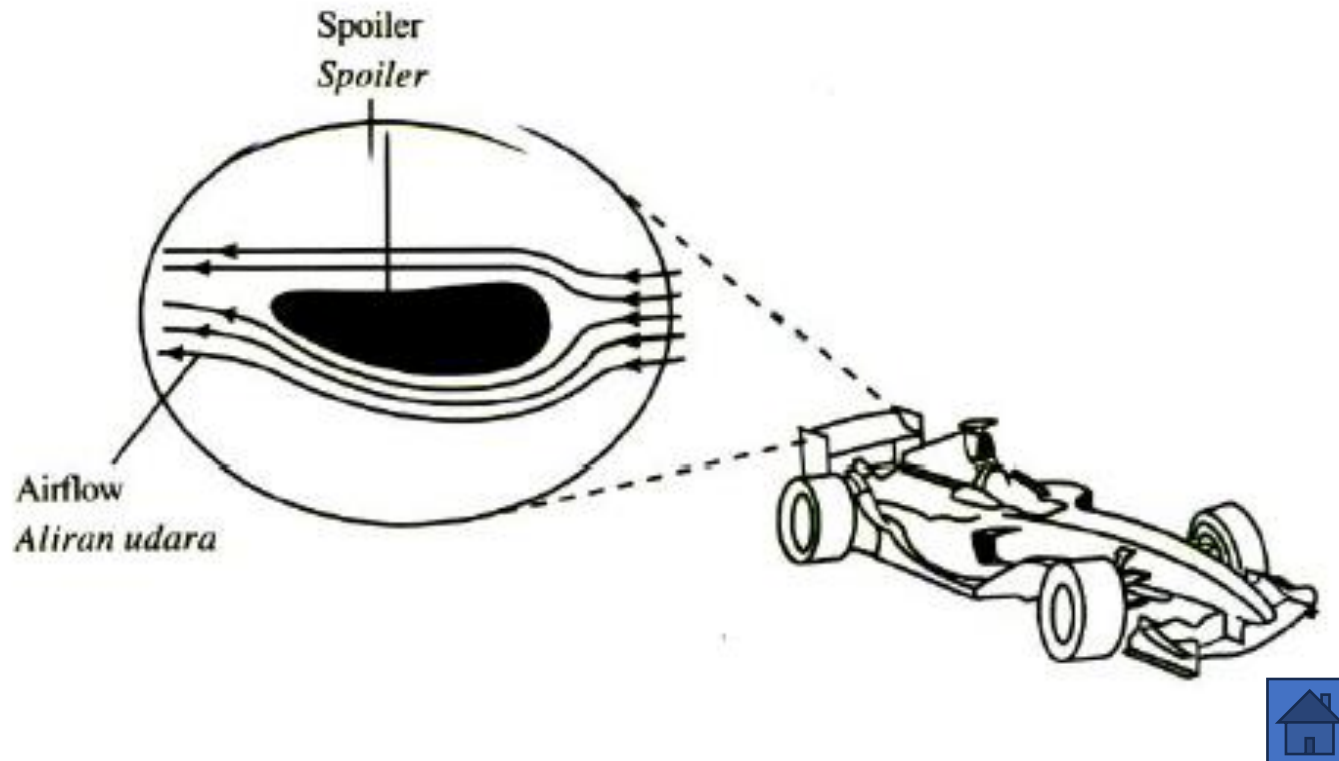

## Section A - 2006

### Question 5

Rajah 20.1 menunjukkan keadaan kertas sebelum dan semasa udara ditiup. Rajah 20.2 menunjukkan keadaan kanopi sebelum lori bergerak dan semasa lori bergerak dengan laju yang tinggi.

Diagram 20.1 shows the situations of a sheet of paper before and when air is blown. Diagram 20.2 shows the situation of the canopy before the lorry moves and when the lorry moves at high speed.

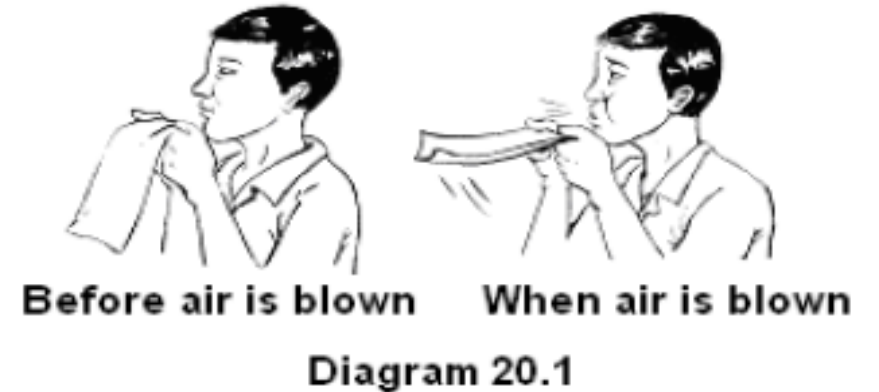

(e) Apakah maksud laju?

What is meant by speed? [1 mark]

**Distance/time**

**Jarak / masa**

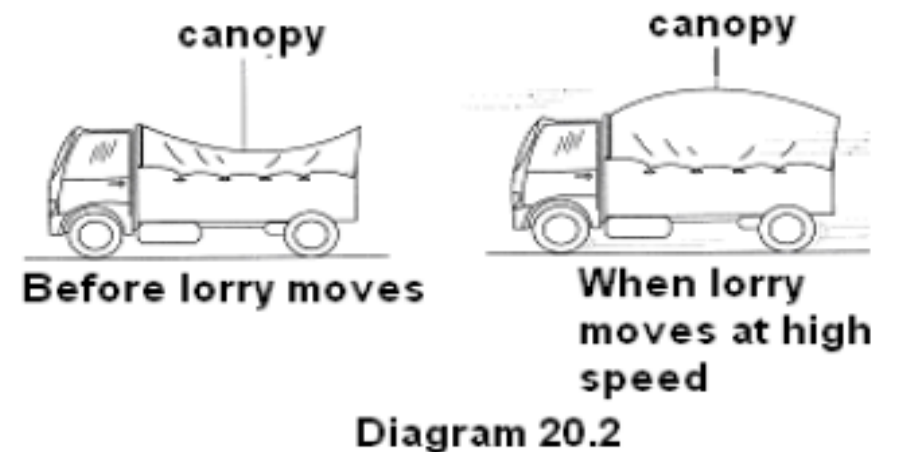

(f) Berdasarkan Rajah 20.1 dan Rajah 20.2:

Based on Diagram 20.1 and Diagram 20.2:

(i) Nyatakan dua kesamaan bagi situasi dalam Rajah 20.1 dan 20.2.

State two similarities for the situations in Diagram 20.1 and Diagram 20.2.

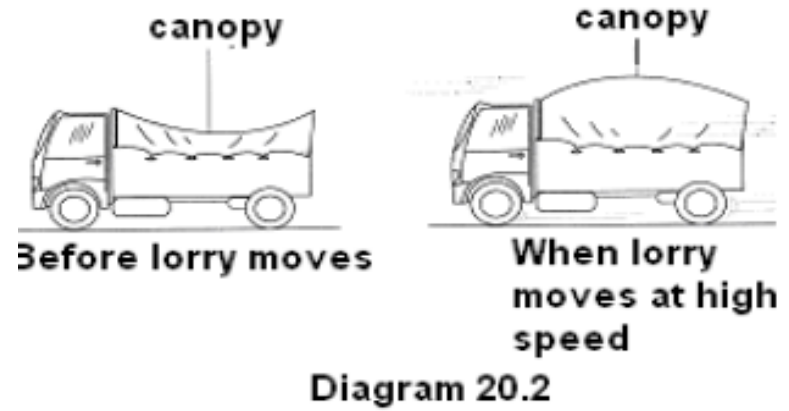
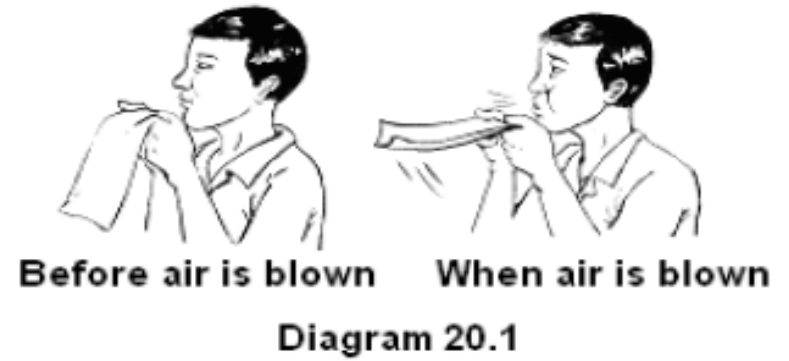

**If no air movement, the paper and the canopy will not lift up/** Jika tiada pergerakan udara,

**kertas dan kanopi tidak terangkat**

**Paper and canopy lift up when the air moves**

**Jika ada gerakan udara, kertas dan kanopi terangkat ke atas**

(ii) Bandingkan tekanan udara di bahagian atas dan bawah kertas itu semasa udara ditiup.

Compare the air pressure above and below the paper when air is blown.

**Pressure above < pressure below**

**Tekanan di atas < tekanan di bawah**



- (iii) Hubungkan laju udara dengan tekanan udara

*Relate the speed of the air to the pressure of the air.*

[1]

**High speed air, low pressure region**  
**laju tinggi, Kawasan tekanan rendah**

- (g) Namkan prinsip yang terlibat di 5(b)(iii).  
*Name the principle involved in 5(b)(iii).*

**Bernoulli's principle**  
**Prinsip Bernoulli**



Before air is blown      When air is blown

Diagram 20.1

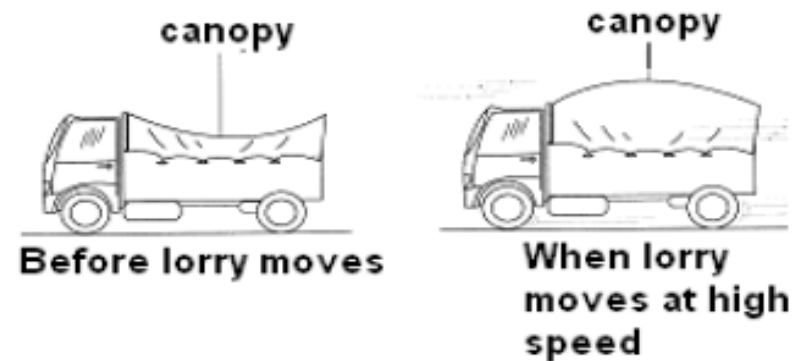

Before lorry moves

When lorry moves at high speed

Diagram 20.2



- (h) Rajah 20.3 menunjukkan alat yang digunakan untuk mengukur laju udara.  
*Diagram 20.3 shows an instrument used to measure the speed of air.*

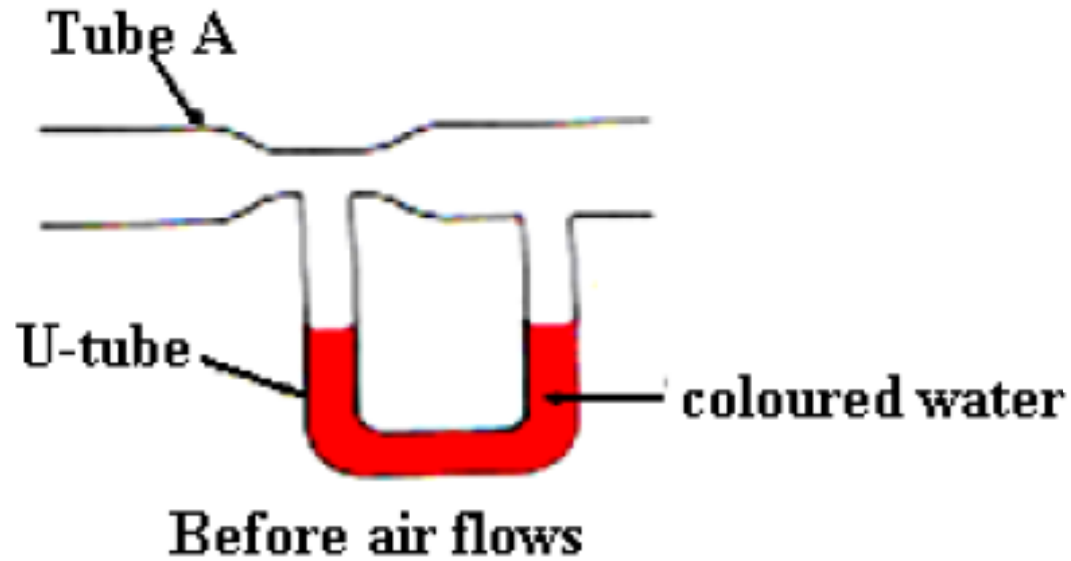

Dalam Rajah 20.3, paras air berwarna dalam tiub-U adalah sama sebelum udara dialirkan.  
*In Diagram 20.3, the levels of coloured water in the U-tube are the same before air flows.*

- (i) Bandingkan laju udara di P dan di Q.  
*Compare the speeds of air at P and at Q*

$$P > Q$$

- (ii) Tandakan aras air dalam tiub-U pada Rajah 5.3 semasa udara dialirkan.  
*Mark the water levels in the U-tube in Diagram 5.3 while air flows.*

[1]

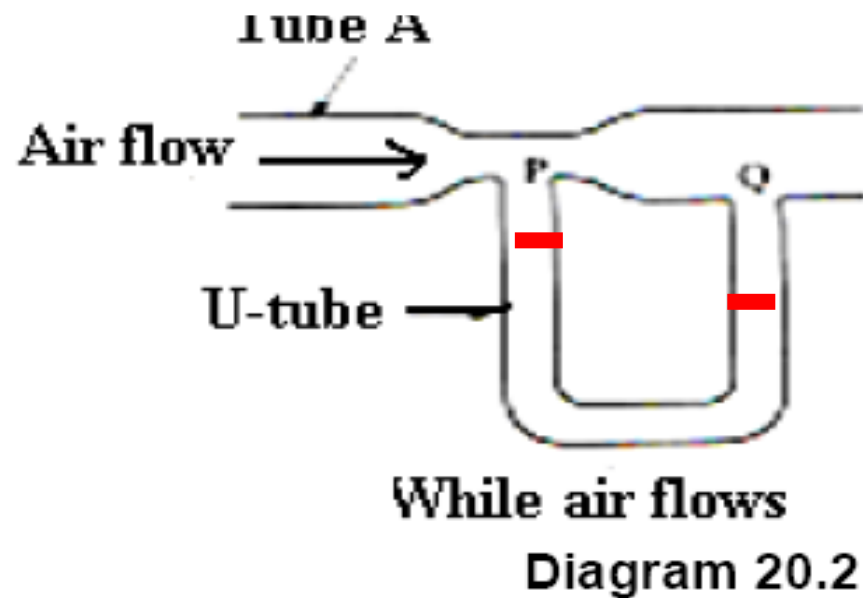

10. Rajah 10.1 menunjukkan seorang pesakit menjalani pemindahan darah. Darah mengalir dari beg darah ke dalam salur darah pesakit berdasarkan konsep tekanan.

Diagram 10.1 shows a patient undergoes a blood transfusion. The blood flows from the blood bag into the patient's vein based on the concept of pressure.

(a) Apakah maksud tekanan? [1 m]

What is the meaning of pressure?

**Tekanan = Daya per unit luas**

**Pressure is force per unit area**

**Tekanan =  $\frac{\text{Daya}}{\text{Luas}}$**

**Pressure =  $\frac{\text{Force}}{\text{Area}}$**

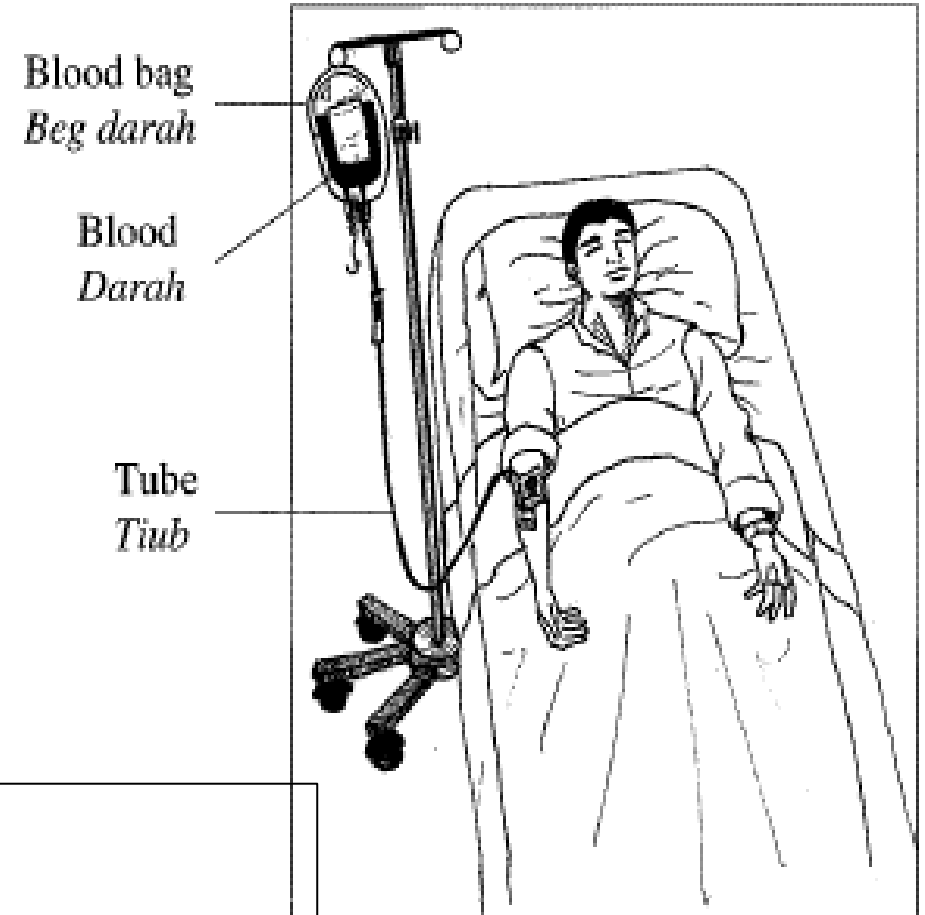

(b) Terangkan bagaimana darah mengalir dari beg darah ke dalam salur darah pesakit.

Explain how blood flows from the blood bag into the patient's vein. [4 m]

**M1 Blood at higher position compared to the vein**

**Darah pada kedudukan lebih tinggi berbanding dengan salur darah /**

**M2  $P = \rho gh$  /  $P \propto h$  /  $P \propto H$**

**M3 The pressure of the blood in the bag  $>$  in the vein // Tekanan darah dalam bag  $>$  dalam salur darah**

**M4 Difference pressure produced //**

**Terhasil perbezaan tekanan**

**M5 Force = Pressure x Area // Daya = tekanan x luas / Darah ditolak / Blood is forced**

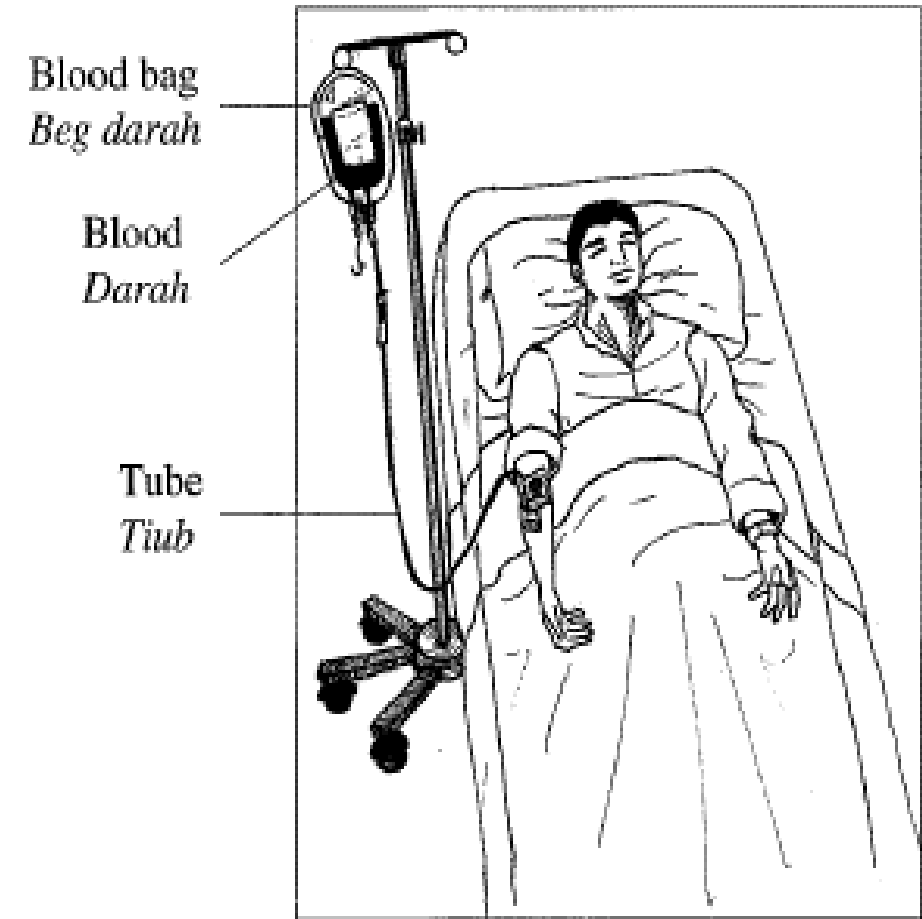

**(c) Satu sistem pengairan air perlu disediakan dalam sebuah taman untuk membekalkan air kepada tumbuhan-tumbuhan. Empat sistem pengairan J, K, L dan M yang boleh mengepam air dari sebuah perigi yang dalam dicadangkan seperti yang ditunjukkan di dalam Jadual 10.**

**A watering system needs to be set up in a garden to supply water to the plants. Four watering systems J, K, L and M which can pump water from a deep well are suggested as shown in Table 10.**

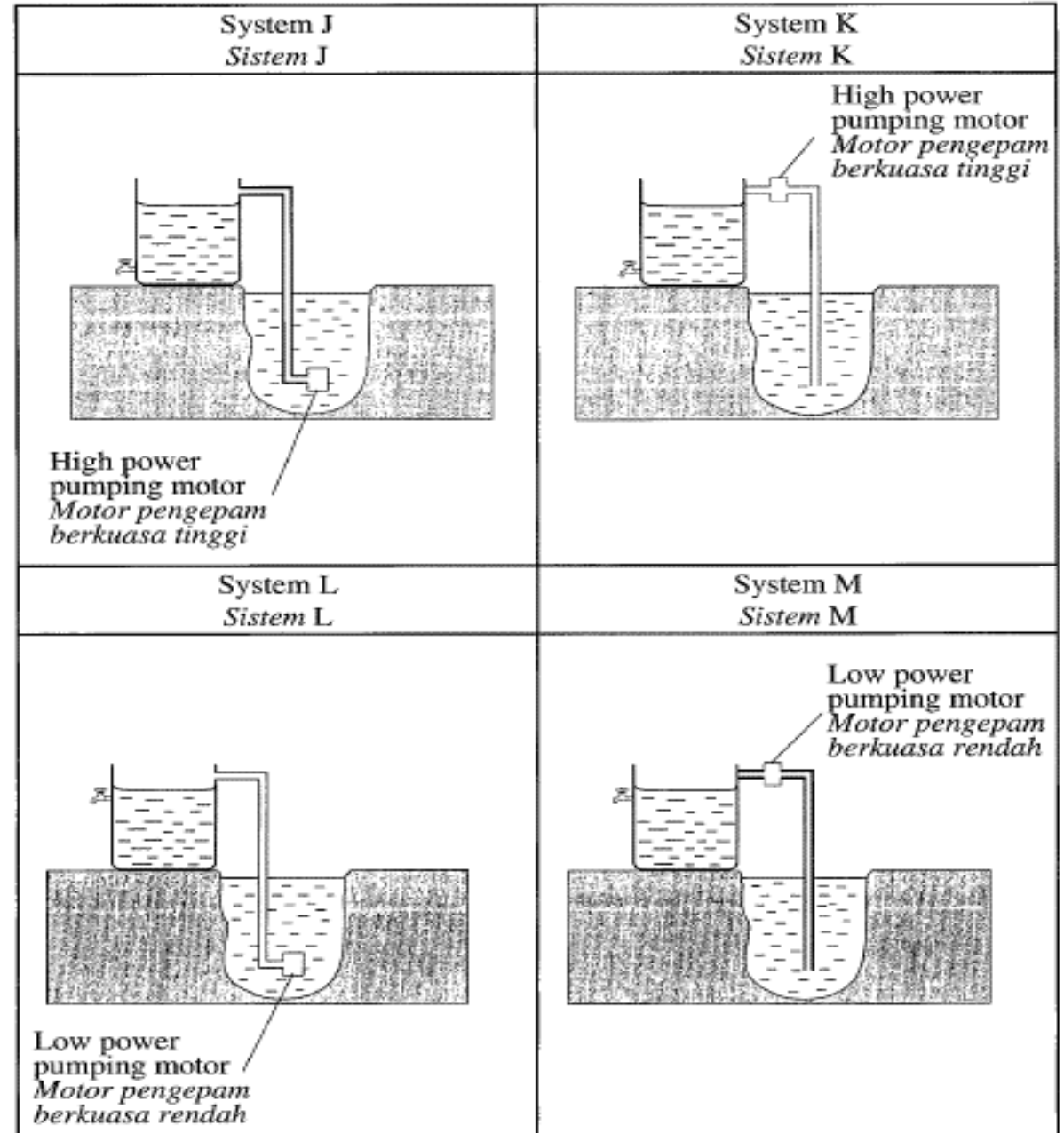

**Kaji spesifikasi keempat-empat sistem pengairan tersebut berdasarkan aspek-aspek berikut:**

**Study the specifications of the four watering systems based on the following aspects:**

- **ketebalan paip**  
**the thickness of the pipe**
- **kuasa motor pengepam**  
**the power of the pumping motor**
- **kedudukan motor pengepam**  
**the position of the pumping motor**
- **kedudukan pil dari permukaan tanah**  
**the position of the tap from the ground surface.**

**Terangkan kesesuaian setiap ciri sistem pengairan tersebut. Tentukan sistem pengairan yang paling sesuai untuk mengepam air dari sebuah perigi yang dalam ke dalam tangki air dan membekalkan air yang cukup untuk tumbuh-tumbuhan. Beri sebab-seba untuk pilihan anda. Explain the suitability of each characteristics of the watering system. Determine the most suitable watering system to pump water from a deep well into a water tank and supply enough water for the plants. Give reasons for your choice.**

**[10 marks]**

**M1 Paip tebal /  
thick pipe**

**M2 Strong / withstand high pressure / kuat / tahan  
tekanan tinggi / tidak bocor / not break / not leaking**

**M3 motor kuasa tinggi  
/ high power motor**

**M4 Daya tinggi / large force / pump more water / pam  
air dengan banyak / air laju / pam kuat**

**M5 motor in the  
well / motor dalam  
perigi**

**M6 Push / overcome high pressure / tolak / atasi tekanan  
tinggi.**

**M7 tap closer to the  
base of tank / pili  
hampir ke dasar**

**M8 water emerges from the tap with high pressure / air  
keluar dari pili dengan tekanan tinggi.**

**M9 J**

**M10 Thick pipe, high power pump, in the well, tap closer to the base // Paip  
tebal, pam kuasa tinggi, dalam perigi, pili dalam perigi, pili hampir ke dasar  
tangki**

**(d) Ketinggian sebuah tangki air dari satu pili dalam rumah ialah 15.2 m. Luas permukaan pili ialah  $4.8 \times 10^{-4} \text{ m}^2$ . [Ketumpatan air =  $1\,000 \text{ kg m}^{-3}$ ; Tekanan atmosfera =  $1.02 \times 10^5 \text{ Pa}$ ]**

**The height of a water tank from a tap in a house is 15.2 m. The surface area of the tap is  $4.8 \times 10^{-4} \text{ m}^2$ .**

**[Density of water =  $1\,000 \text{ kg m}^{-3}$ ; Atmospheric pressure =  $1.02 \times 10^5 \text{ Pa}$ ]**

**Hitung**

**Calculate**

**(i) Jumlah tekanan air yang mengalir keluar dari pili**

**The total pressure of water that flows out from the tap.**

$$\begin{aligned} & (1000)(15.2)(10) = 1.52 \times 10^5 \\ P_{\text{air}} + P_{\text{atm}} & 1.52 \times 10^5 + 1.02 \times 10^5 \\ & = 2.54 \times 10^5 // 254,000 \end{aligned}$$

**(ii) Daya yang menolak air keluar dari pili.**

**The force that pushes the water out from the tap.**

**[Luas permukaan pili =  $4.8 \times 10^{-4} \text{ m}^2$ ]**

**[Surface area of the tap =  $4.8 \times 10^{-4} \text{ m}^2$ ]**

$$F = PA$$

$$\begin{aligned} F &= (2.54 \times 10^5) (4.8 \times 10^{-4}) \\ &= 121.92 \text{ N} \end{aligned}$$

**[5 markah]**

## Section B - 2017

### Section C Question 11

Diagram 11.1 shows a vessel which has 2 holes, X and Y at difference height. When the vessel is filled with water, water spurts out from the two holes due to the water pressure.

Rajah 11.1 menunjukkan sebuah balang yang mempunyai 2 lubang, X dan Y pada ketinggian yang berlainan. Apabila balang tersebut diisi dengan air, air terpancut keluar daripada dua lubang tersebut disebabkan oleh tekanan air.

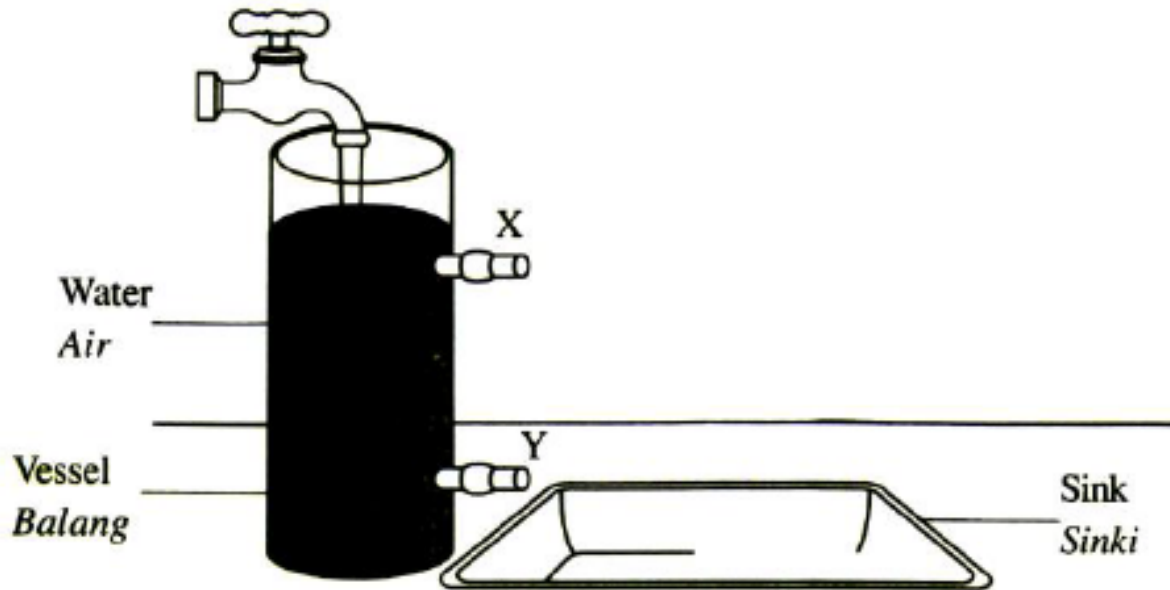

Diagram 11.1 / Rajah 11.1

- (a)(i) What is the meaning of *pressure*?  
*Apakah maksud tekanan?*

[1 mark]

$$\text{Pressure} = \frac{\text{Force}}{\text{Area}}$$

//force per area//**Daya per luas**



(ii) In your answer sheet, draw the path of the water which spurts out from the holes X and Y.

*Dalam helaian jawapan anda, lukis lintasan air yang terpancut keluar dari lubang X dan Y.*

[2 marks]

(iii) What happens to the distance of the liquid spurting out a hole X when water is replaced by salt solution? Explain your answer.

*Apakah yang berlaku pada jarak pancutan air yang keluar dari lubang X apabila air digantikan dengan larutan garam? Terangkan jawapan anda.*

[3 marks]

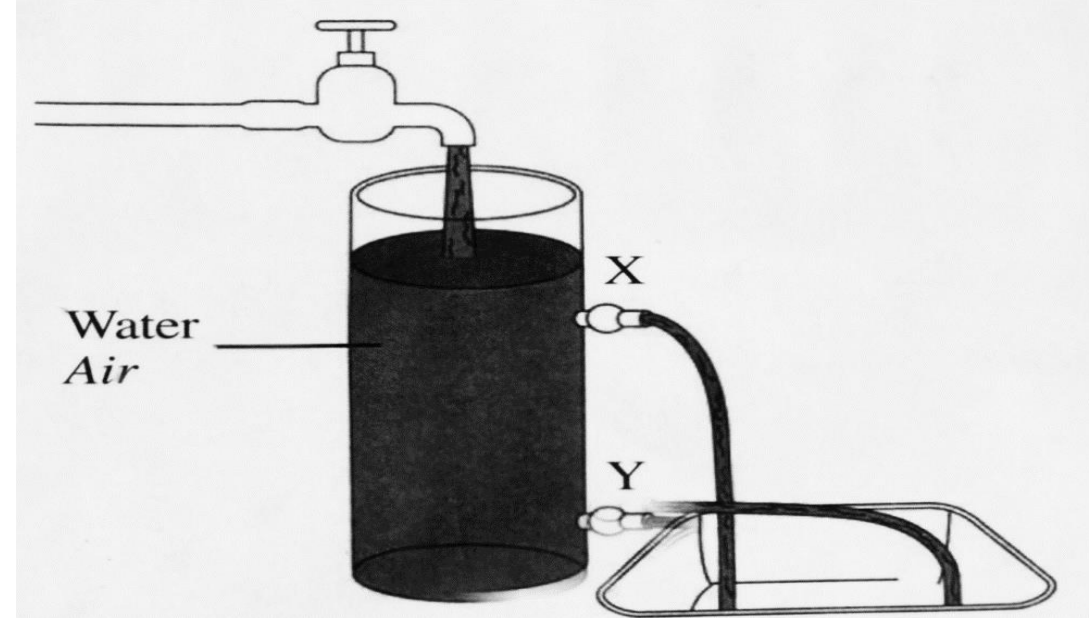

✓<sup>1</sup> **Distance increase //large distance**

**//jarak tambah //jarak lebih/besar**

✓<sup>2</sup> **density large / ketumpatan tinggi**

✓<sup>3</sup> **Pressure directly proportional to density //high pressure**

**/ tekanan berkadar terus dengan ketumpatan //P = ρgh**



## Section B - 2017

- (b) Diagram 11.2 shows a car's hydraulic brake system. A 15 N force is applied to the brake pedal. The cross-sectional area of the master piston and the slave piston are  $2.84 \times 10^{-4} \text{ m}^2$  and  $1.13 \times 10^{-3} \text{ m}^2$  respectively. *Rajah 11.2 menunjukkan system brek hidraulik sebuah kereta. Daya 15 N dikenakan kepada pedal brek. Luas keratan rentas untuk omboh utama dan omboh kedua adalah masing-masing  $2.84 \times 10^{-4} \text{ m}^2$  and  $1.13 \times 10^{-3} \text{ m}^2$ .*

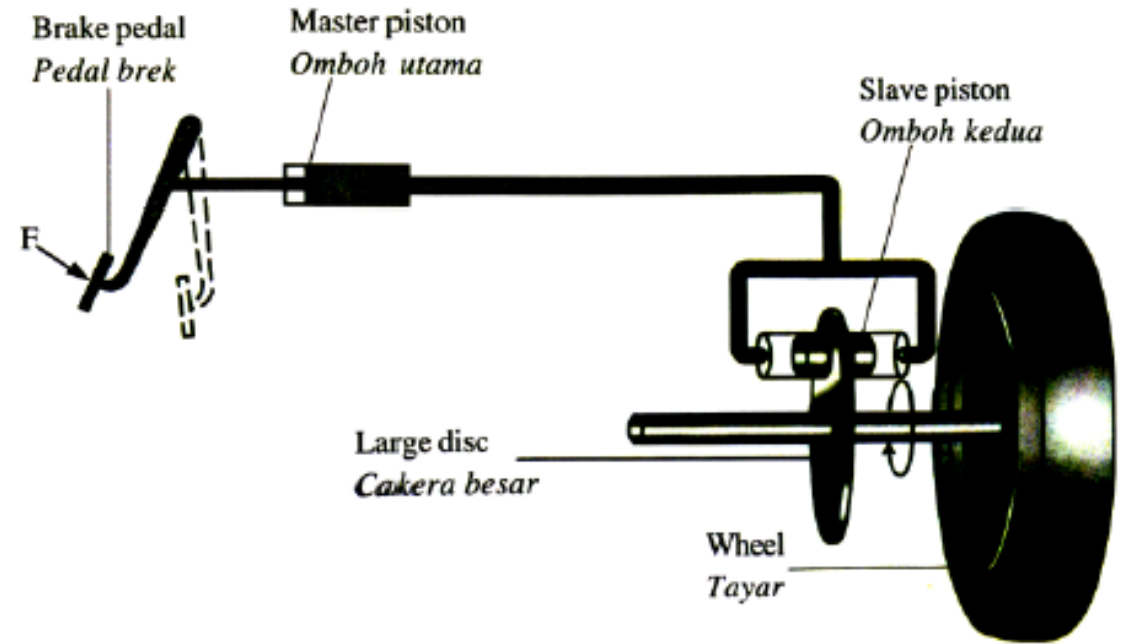

**Calculate**

*Hitung*

- (i) The pressure acted on the master piston.

*Tekanan yang bertindak ke atas omboh utama.*

[2 marks]

- (ii) The force produced on the slave piston.

*Daya dihasilkan pada omboh kedua.*

[2 marks]

**b)(i)  $\sqrt{1} \ 15 / 2.84 \times 10^{-4}$**

**$\sqrt{2} \ 5.28 \times 10^4 \text{ Pa} // 52816.9 \text{ Pa}$**

**(b)(ii)**

**$\sqrt{1} \ 5.28 \times 10^4 \times 1.13 \times 10^{-3}$   
 **$// 5.28169 \times 1.13 \times 10^{-3}$****

**$\sqrt{2} \ 59.68 \text{ N}$**



(c) Diagram 11.3 shows a truck uses a hydraulic system to unload sand from the tipper in a construction area.

Rajah 11.3 menunjukkan sebuah trak yang menggunakan system hidraulik untuk menurunkan pasir dari pelonggok di kawasan pembinaan.

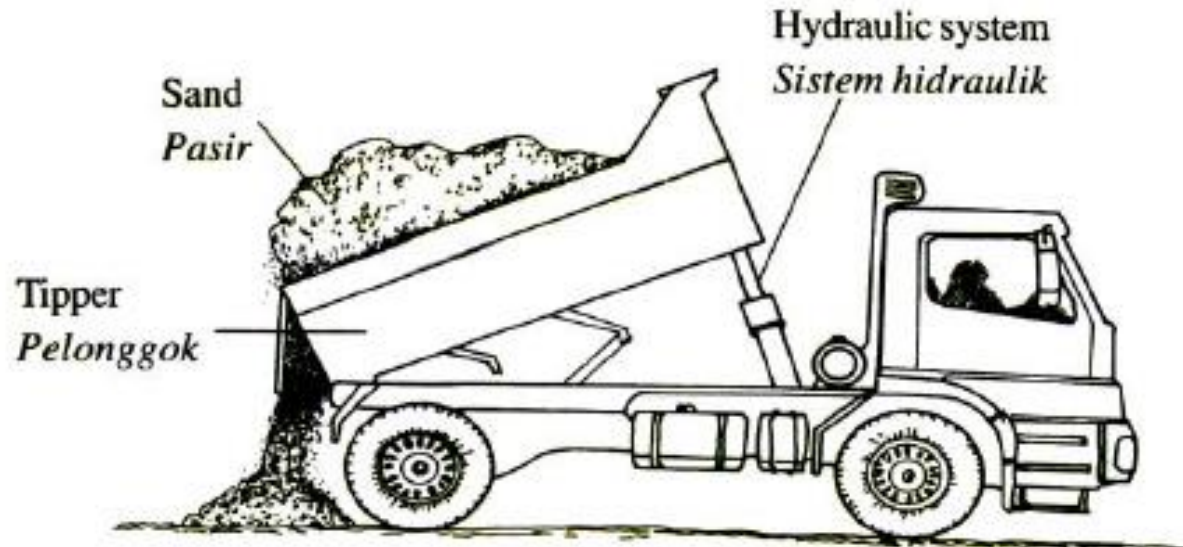

**Study the specification of all the four hydraulic systems. Explain the suitability of each specification of the hydraulic systems and determine the most suitable hydraulic system to be used to unload sand from the tipper. Give reason for your choice.**

Kaji spesifikasi keempat-empat system hidraulik tersebut. Terangkan kesesuaian setiap spesifikasi untuk kesemua system hidraulik dan tentukan system hidraulik yang paling sesuai digunakan bagi menurunkan pasir dari pelonggok. Beri sebab untuk pilihan anda.

[10 marks]

Table 3 shows the characteristics of different hydraulic systems.

Jadual 3 menunjukkan ciri-ciri bagi system hidraulik yang berbeza.

Hydraulic system <i>Sistem hidraulik</i>	The cross-section area of master piston <i>Luas keratan rentas omboh utama</i>	The cross-section area of slave piston <i>Luas keratan rentas omboh kedua</i>	Material used for fluid transmission pipe <i>Bahan yang digunakan untuk paip penghantaran cecair</i>	Boiling point of the hydraulic fluid <i>Takat didih cecair hidraulik</i>
P	Small <i>Kecil</i>	Big <i>Besar</i>	Iron <i>Besi</i>	High <i>Tinggi</i>
Q	Small <i>Kecil</i>	Big <i>Besar</i>	Steel <i>Keluli</i>	High <i>Tinggi</i>
R	Big <i>Besar</i>	Big <i>Besar</i>	Iron <i>Besi</i>	Low <i>Rendah</i>
S	Small <i>Kecil</i>	Small <i>Kecil</i>	Steel <i>Keluli</i>	Low <i>Rendah</i>



√<sup>1</sup> the cross sectional area of master piston: Small // kecil

√<sup>3</sup> the cross sectional area of slave piston: Big // besar

√<sup>5</sup> material for fluid transmission pipe: steel / keluli

√<sup>7</sup> High boiling point //takat didih tinggi

√<sup>9</sup> Q

√<sup>10</sup> small cross sectional area of master piston, big cross sectional area of slave piston, steel, high boiling point.

√<sup>2</sup> To produce high pressure //high pressure//Tekanan tinggi //daya kecil

√<sup>4</sup> Large output force //Daya output besar

√<sup>6</sup> strong //not rust //tidak karat // tidak bocor //tidak patah //withstand high pressure //tahan tekanan tinggi

√<sup>8</sup> does not vaporise //tidak meruap / tidak kering //not dry //prevent boiling



## Section B - 2011

Diagram 11.1 shows a hydraulic jack which is used to lift up a car. The working principle of the hydraulic jack is based on the Pascal's principle.

Rajah 11.1 menunjukkan jek hidraulik yang digunakan untuk mengangkat sebuah kereta. Prinsip kerja jek hidraulik adalah berdasarkan prinsip Pascal.

- (i) State the Pascal's principle.  
Nyatakan prinsip Pascal.

[ 1 mark]

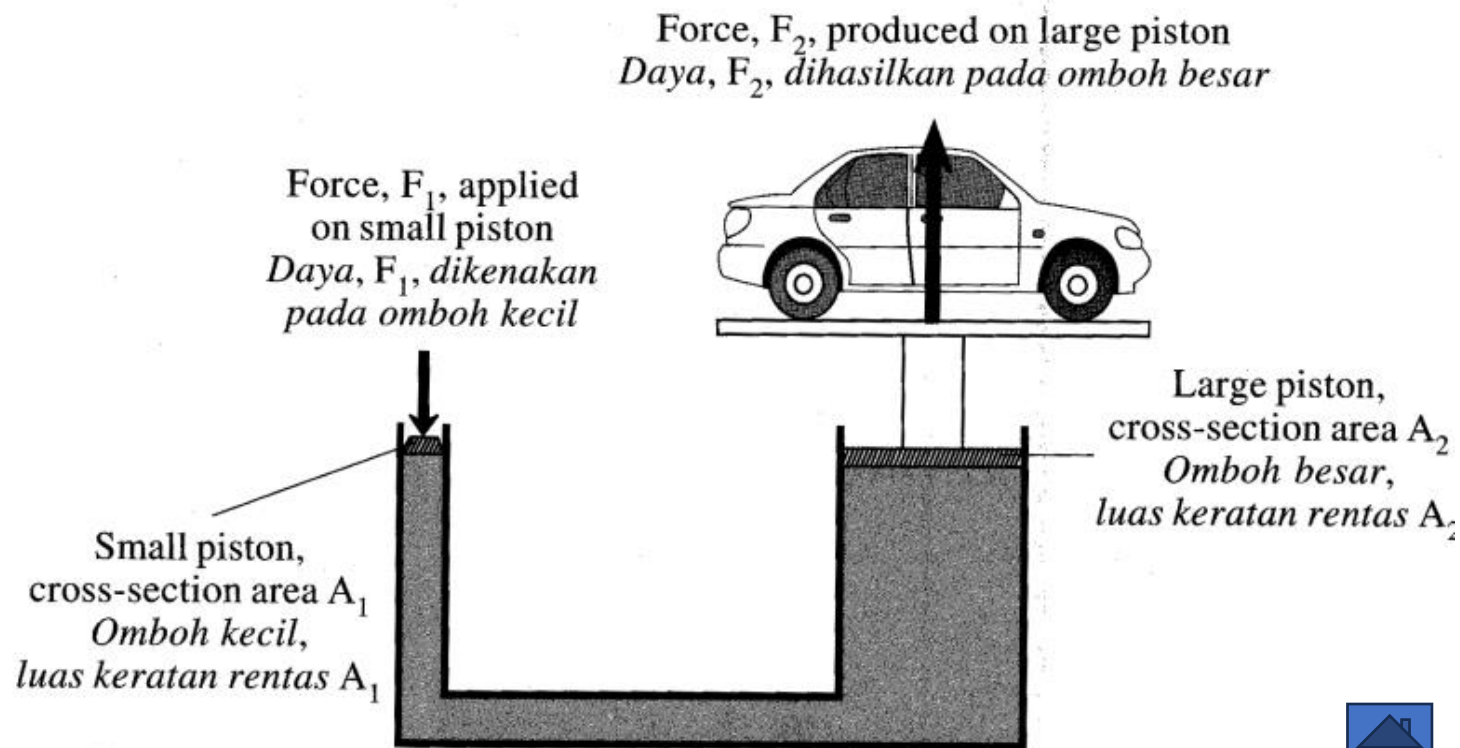

**Liquid pressure is transmitted equally through out all parts of liquid.**

**Tekanan cecair dipindahkan secara seragam ke seluruh bahagian cecair.**



(ii) Explain how the hydraulic jack can be used to lift a car when force  $F_1$  is applied on the small piston with cross-section area  $A_1$ .

In your explanation, state the reason why force  $F_2$  is greater than force  $F_1$ . [4 marks]

*Terangkan bagaimana jek hidraulik boleh digunakan untuk mengangkat sebuah kereta apabila daya  $F_1$  dikenakan pada omboh kecil dengan luas keratan rentas  $A_1$*

*Dalam penerangan anda, nyatakan sebab mengapa daya  $F_2$  lebih besar daripada daya  $F_1$ .*

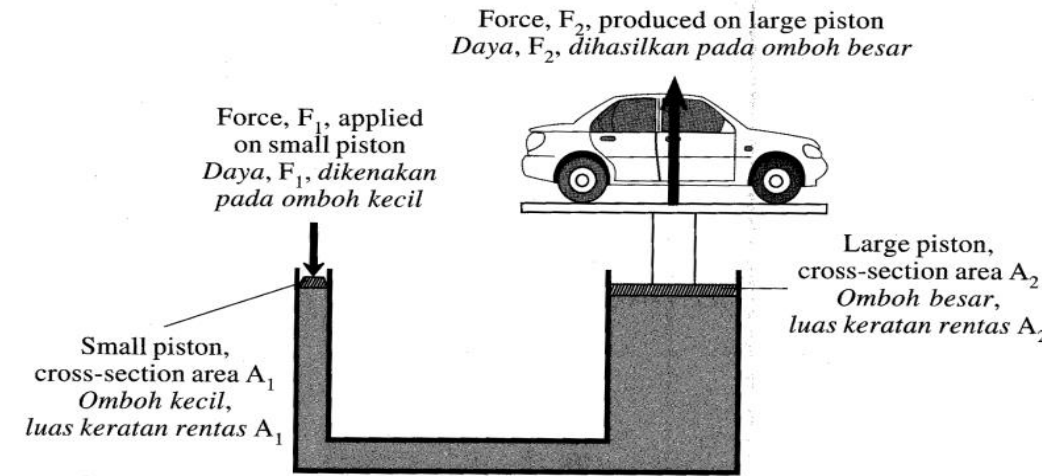

**M1 – force produce pressure /  $P=F/A$  / daya hasilkan tekanan**

**M2 – pressure transmitted equally on  $A_2$  /  $P_1=P_2$  / tekanan dipindahkan secara seragam ke  $A_2$**

**M3 – pressure act on  $A_2$  / pressure produce force / tekanan bertindak pada omboh  $A_2$  //  $F_2 = PA_2$**

**M4 –  $A_2 > A_1$  /  $A_2$  greater /  $A_2$  lebih besar**



(b) Diagram 11.2 shows a hydraulic brake system in a car.

Rajah 11.2 menunjukkan suatu sistem brek hidraulik dalam sebuah kereta.

You are required to investigate the characteristics of a hydraulic brake system as shown in Table 11.

Anda dikehendaki menyiasat ciri-ciri sistem brek hidraulik seperti ditunjukkan dalam Jadual 11.

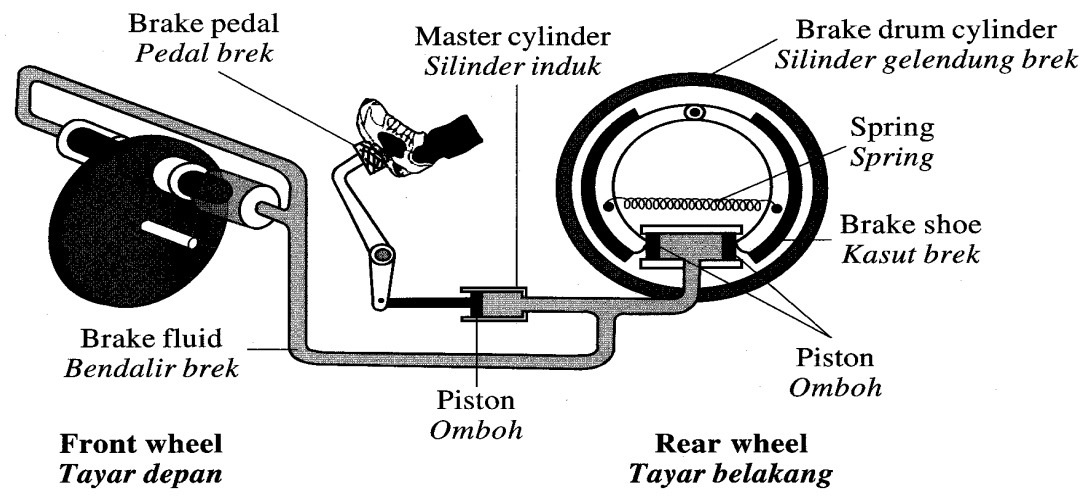

Explain the suitability of each characteristic of the hydraulic brake system. Determine the most effective hydraulic brake to be used in a car brake system. Give reasons for your choice. [10 marks]

Terangkan kesesuaian setiap ciri sistem brek hidraulik. Tentukan brek paling berkesan untuk digunakan dalam sistem brek sebuah kereta. Berikan sebab-sebab untuk pilihan anda. [10 markah]

Hydraulic brake Brek hidraulik	Type of brake fluid Jenis bendalir brek	Boiling point of brake fluid Takat didih bendalir brek	Spring constant of the spring Pemalar spring bagi spring	Ratio of the cross section area of master pistons in master cylinder to the brake drum cylinder - Nisbah luas keratan rentas ombok dalam silinder induk kepada silinder gelendung brek
	Incompressible Tidak boleh dimampatkan	Low Rendah	Low Rendah	1:1
	Compressible Boleh dimampatkan	Low Rendah	High Tinggi	
	Incompressible Tidak boleh dimampatkan	High Tinggi	High Tinggi	
	Compressible Boleh dimampatkan	High Tinggi	High tinggi	5:1



- **M1 – incompressible / tidak boleh dimampatkan**
- **M2 – fluid can transfer / flow / pressure transmitted / obey Pascal Principle / cecair boleh dipindahkan / tekanan dipindahkan**
- **M3 – high boiling point / takat didih tinggi**
- **M4 – not change to vapour / not easy to evaporate/boil / tidak mudah bertukar ke gas / tidak mudah menyejat / didih**
- **M5 – high spring constant / pemalar spring tinggi**
- **M6 – can withstand force / return quickly / boleh tahan daya / mudah kembali**
- **M7 – 1:5 / low ratio / nisbah kecil**
- **M8 – larger force / easy to stop / daya tinggi / mudah berhenti**
- **M9 – L**
- **M10 – because it is incompressible, has high boiling point, high spring constant and low ration (1:5)**



- (c) In a hydraulic brake system, the cross-section area of the pistons in the master cylinder and the front wheel are  $2 \text{ cm}^2$  and  $6 \text{ cm}^2$  respectively. A force of  $50 \text{ N}$  is applied to the piston in the master cylinder.

*Dalam suatu sistem brek hidraulik, luas keratan rentas omboh dalam silinder induk dan di tayar depan masing-masing adalah  $2 \text{ cm}^2$  dan  $6 \text{ cm}^2$ . Daya  $50 \text{ N}$  dikenakan ke atas omboh dalam silinder induk.*

Calculate/ Hitung

- (i) the pressure transmitted throughout the brake fluid.

*tekanan yang dipindahkan ke seluruh bendalir brek.*

[2 marks]

- (ii) the force exerted on the piston of the front wheel.

*daya yang dikenakan ke atas omboh tayar depan.*

[3 marks]

**M1:  $50/2$**

**M2:  $25 \text{ N cm}^{-2}$**

**M1:  $50/2 \times 10^{-4}$**

**M2:  $2.5 \times 10^5 \text{ Pa}$**

**M1:  $F_1/A_1 = F_2/A_2 = 25$**

**M2:  $F_2 = 25 \times 6$**

**M3:  $150 \text{ N}$**



## Section B - 2013

- (a) Diagram 11.1 shows the cross section of the wing of an aeroplane.

*Rajah 11.1 menunjukkan keratan rentas sebuah sayap kapal terbang.*

- (i) Name the shape of the aeroplane's wing.

*Namakan bentuk sayap kapal terbang. [1 mark]*

**Aerofoil**

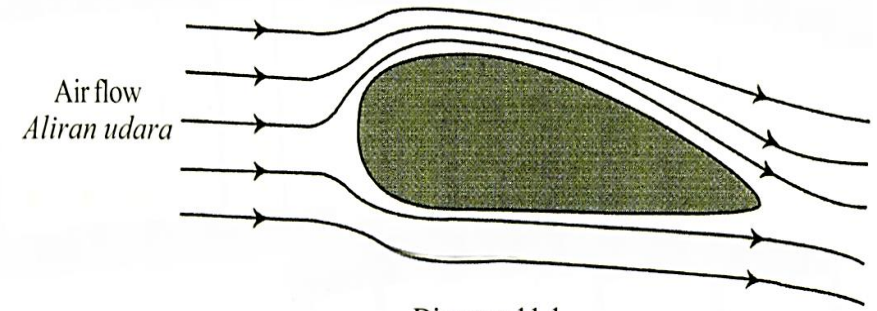

Diagram 11.1  
*Rajah 11.1*



(ii) Explain how the aeroplane can lift up from the track when it moves at high speed during take off.

*Terangkan bagaimana kapal terbang boleh diangkat daripada landasan apabila ia bergerak dengan laju yang tinggi semasa berlepas.*

[4 marks]

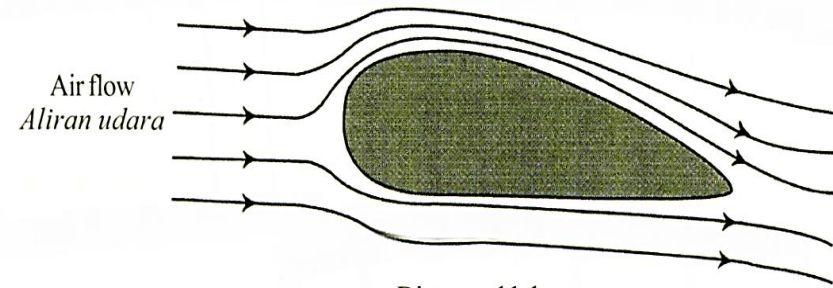

Diagram 11.1  
Rajah 11.1

✓<sup>1</sup> **Air faster (at) top / udara di atas laju**

✓<sup>2</sup> **Small pressure (at) upper / tekanan rendah di atas**

✓<sup>3</sup> **difference in pressure // terdapat perbezaan tekanan /  $P_2 - P_1$  /**

**$P_1 - P_2$**

✓<sup>4</sup> **Lift / upward force //  $F = PA$  //  $F$  //  $PA$  // daya angkat ke atas**

✓<sup>5</sup> **Bernoulli's principle / Prinsip Bernoulli**

**Max 4 marks**



- (b) An aeroplane with mass of  $3.6 \times 10^5$  kg and total surface area of  $460 \text{ m}^2$  is at a constant height. The resultant force acting on the aeroplane at that moment is zero.

*Sebuah kapal terbang dengan jisim  $3.6 \times 10^5$  kg dan jumlah luas permukaan ialah  $460 \text{ m}^2$  pada ketinggian yang malar. Daya paduan bertindak ke atas kapal terbang pada ketika itu ialah sifar.*

- (i) Calculate the weight of the aeroplane.  
*Hitung berat kapal terbang.*

$$3.6 \times 10^6 \text{ N}$$

[1 mark]

- (ii) Determine the lifting force acting on the aeroplane.

*Tentukan daya angkat yang bertindak ke atas kapal terbang.*

$$3.6 \times 10^6 \text{ N}$$

[1 mark]

- (iii) Based on the answer in 11(b)(ii), calculate the pressure difference between the upper and lower surfaces of the wings of the aeroplane.  
*Berdasarkan kepada jawapan di 11(b)(ii), hitung perbezaan tekanan antara bahagian atas dan bawah permukaan sayap kapal terbang.*

[3 marks]

$$\sqrt{1} \quad 3.6 \times 10^6 = P_1 A - P_2 A$$

$$\sqrt{2} \quad \text{Pressure difference} = (3.6 \times 10^6 / 460)$$

$$\sqrt{3} \quad 7826.09 \text{ Pa}$$



(c) Diagram 11.2 shows four design of perfume sprays, P, Q, R and S with different specifications. You are required to determine the most suitable design of a perfume spray to produce a fine spray. Study the specifications of the four perfume sprays based on the following aspects:

Rajah 11.2 menunjukkan empat reka bentuk penyembur minyak wangi P, Q, R dan S dengan spesifikasi yang berbeza. Anda dikehendaki menentukan reka bentuk penyembur minyak wangi yang paling sesuai untuk menghasilkan semburan halus. Kaji spesifikasi keempat-empat reka bentuk penyembur minyak wangi berdasarkan kepada aspek-aspek berikut:

- (i) **Size of the squeeze bulb.**  
Saiz bola pemicit
- (ii) **Elasticity of the squeeze bulb.**  
Kekenyalan bola pemicit
- (iii) **Shape of the mid tube**  
Bentuk tiub tengah
- (iv) **Size of the nozzle.**  
Saiz muncung

**Explain the suitability of each aspect and then determine the most suitable design of a perfume spray. Give reason for your choice.**

Terangkan kesesuaian setiap aspek dan kemudian tentukan reka bentuk penyembur minyak wangi yang paling sesuai. Beri sebab bagi pilihan anda.

[10 marks]

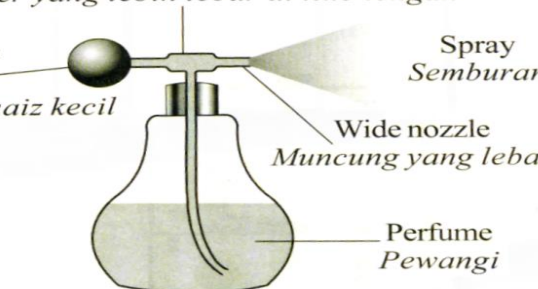
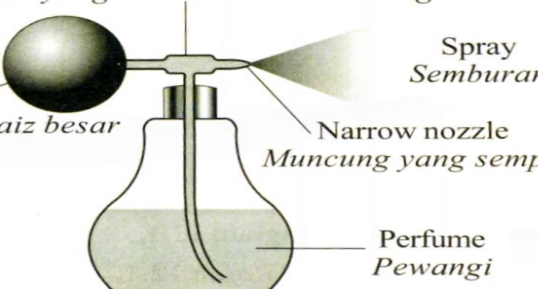
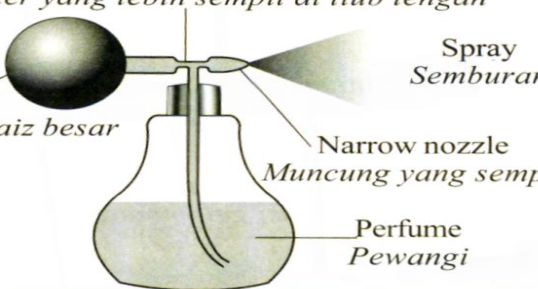
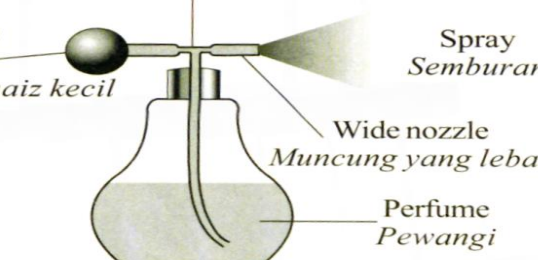
<p>Perfume spray P Penyembur pewangi P</p>	<p>Wider diameter of mid tube <i>Diameter yang lebih lebar di tiub tengah</i></p> <p>Inelastic small size squeeze bulb <i>Bola pemicit bersaiz kecil yang tak kenyal</i></p> <p>Wide nozzle <i>Muncung yang lebar</i></p> <p>Spray Semburan</p> <p>Perfume Pewangi</p> 
<p>Perfume spray Q Penyembur pewangi Q</p>	<p>Wider diameter of mid tube <i>Diameter yang lebih lebar di tiub tengah</i></p> <p>Elastic big size squeeze bulb <i>Bola pemicit bersaiz besar yang kenyal</i></p> <p>Narrow nozzle <i>Muncung yang sempit</i></p> <p>Spray Semburan</p> <p>Perfume Pewangi</p> 
<p>Perfume spray R Penyembur pewangi R</p>	<p>Narrow diameter of mid tube <i>Diameter yang lebih sempit di tiub tengah</i></p> <p>Elastic big size squeeze bulb <i>Bola pemicit bersaiz besar yang kenyal</i></p> <p>Narrow nozzle <i>Muncung yang sempit</i></p> <p>Spray Semburan</p> <p>Perfume Pewangi</p> 
<p>Perfume spray S Penyembur pewangi S</p>	<p>Narrow diameter of mid tube <i>Diameter yang lebih sempit di tiub tengah</i></p> <p>Inelastic small size squeeze bulb <i>Bola pemicit bersaiz kecil yang tak kenyal</i></p> <p>Wide nozzle <i>Muncung yang lebar</i></p> <p>Spray Semburan</p> <p>Perfume Pewangi</p> 



- √<sup>1</sup> **Big squeeze bulb / bola pemicit besar**
- √<sup>2</sup> **contain more air, produce greater pressure / banyak udara / tekanan tinggi**
- √<sup>3</sup> **Elastic squeeze bulb / bola pemicit kenyal**
- √<sup>4</sup> **Less compression force required // easy to return to original shape / kurang daya mampatan diperlukan // mudah kembali ke bentuk asal**
- √<sup>5</sup> **narrower diameter of mid tube / diameter lebih sempit di tiub tengah**
- √<sup>6</sup> **Air travel faster to create lower pressure**  
**udara gerak laju untuk hasilkan Kawasan tekanan rendah.**
- √<sup>7</sup> **narrow nozzle / muncung yang sempit**
- √<sup>8</sup> **Liquid carried out from the nozzle in a tiny droplets // large coverage**  
**// increase coverage / area / liputan luas / Kawasan liputan luas /**
- √<sup>9</sup> **Perfume spray R**
- √<sup>10</sup> **Big size of squeeze-bulb, elastic squeeze-bulb, narrower shape of the tube at the middle and small size of nozzle**



**Question 9, Section B**

Rajah menunjukkan kesan tekanan ke atas pasir di tepi pantai apabila seorang lelaki sedang duduk di atas kerusi. Rajah 9.2 menunjukkan lelaki yang sama duduk di atas kerusi yang sama selepas diletakkan sekeping papan di bawah kerusi itu.

*Diagram 9.1 shows the effect of pressure on a sandy beach when a man sits on a chair. Diagram 9.2 shows the same man sitting on the same chair after a piece of plank is placed under the chair.*

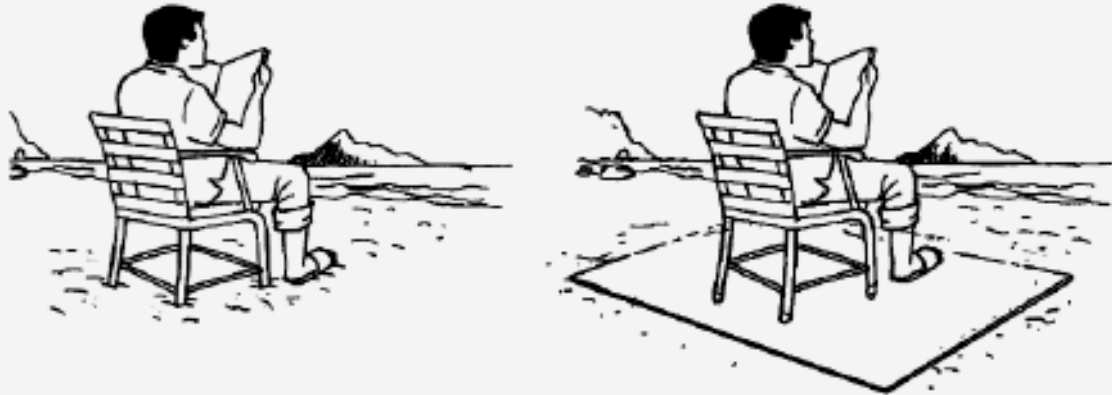

Diagram 9.1  
Rajah 9.1

Diagram 9.2  
Rajah 9.2

- (i) Apakah maksud tekanan?  
What is the meaning of pressure?  
[1 mark]

$$\text{Pressure} = \frac{\text{Force}}{\text{Area}}$$

$$\text{Tekanan} = \frac{\text{Daya}}{\text{Luas}}$$



- (ii) Perhatikan Rajah 9.1 dan Rajah 9.2. Bandingkan kedalaman bahagian yang tenggelam, beban dan luas kawasan yang bersentuhan dengan pasir di pantai itu. Hubungkan kedalaman bahagian yang tenggelam dengan tekanan yang dikenakan oleh kerusi untuk membuat kesimpulan tentang hubungan antara tekanan dengan luas kawasan yang bersentuhan dalam situasi ini.

*Observe Diagram 9.1 and Diagram 9.2.*

*Compare the depth of sinking, the load and the area of contact with the sandy beach.*

*Relate the depth of sinking with the pressure exerted by the chair to make a deduction on the relationship between the pressure and the area of contact in this situation.*

[5 marks]

**Depth of sinking:  $9.1 > 9.2$**

**Kedalaman bahagian tenggelam:**

**Weight / load : equal**

**Berat / beban: sama**

**Area of contact:  $9.1 < 9.2$**

**Luas Kawasan sentuhan:**

**Depth increases, pressure increases**

**Kedalaman bertambah, tekanan bertambah**

**Area increase, pressure decrease**

**Luas bertambah, tekanan berkurang**



## Section C - 2009

(b) Rajah 9.3 menunjukkan sebuah pembersih vakum.

*Diagram 9.3 shows a vacuum cleaner.*

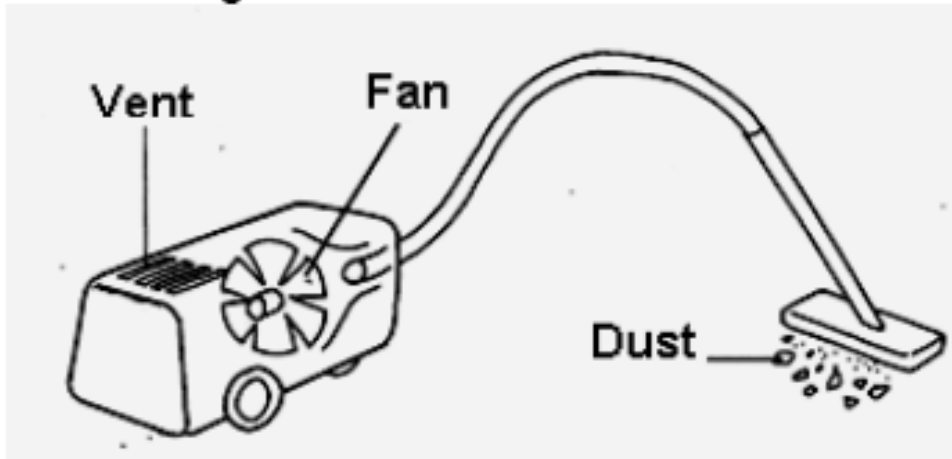

Terangkan bagaimana pembersih vakum itu dapat membersihkan lantai daripada habuk.

*Explain how the vacuum cleaner is able to remove dust from the floor.*

[4 marks]

**Fan blows or suck air out**  
**Kipas sedut udara keluar**

**Produce vacuum / low pressure**  
**in the vacuum cleaner**  
**Hasilkan vakum / tekanan**  
**rendah dalam pembersih vakum**

**Produce difference in pressure**  
**or atmospheric pressure is**  
**higher than pressure inside**  
**Hasilkan perbezaan tekanan /**  
**tekanan atmosfera lebih tinggi**

**This will force / pushed the dirt into the vacuum**  
**cleaner / ini akan tolak habuk ke pembersih vakum**



- (c) A car needs an efficient hydraulic brake system for safety purposes. Suggest and explain how to build a hydraulic brake system which can function effectively, based on the following aspect:

*Sebuah kereta memerlukan satu sistem brek hidraulik yang cekap untuk tujuan keselamatan. Cadang dan terangkan bagaimana untuk membina satu sistem brek hidraulik yang dapat berfungsi secara berkesan berdasarkan aspek-aspek berikut:*

- (i) **The type and characteristics of the brake fluid.**  
*Jenis dan ciri cecair brek.*
- (ii) **The size of the master piston and slave piston.**  
*Saiz piston pertama dan piston kedua.*
- (iii) **The material used for the fluid transmission pipe.**  
*Bahan digunakan untuk paip transmisi cecair.*

[10 marks]



**Type of fluid: oil**  
**Jenis cecair: minyak**

**Cannot be compressed / no air bubble / tidak boleh dimampatkan / tiada gelumbung udara**

**High boiling point**  
**Takat didih tinggi**

**Does not change to gasses state**  
**Tidak bertukar ke gas**

**Low density fluid**  
**Cecair ketumpatan rendah**

**Lighter**  
**ringan**

**Size of master piston small**  
**/ Saiz piston pertama kecil**

**To produce high pressure / small input force/ Tekanan tinggi / daya input kecil**

**Size of slave piston big**  
**Saiz piston kedua besar**

**To produce big output force / force directly proportional to area / daya output besar / Daya berkadar terus dengan luas**

**Material fluid transmission: aluminium**  
**/ steel / keluli**

**Strong / does not break easily / prevent leakage / kuat / tidak mudah pecah / tidak bocor**



## Section C - 2012

### Question 9 Section B

Rajah 9.1 menunjukkan kedudukan P dan Q pada altitud yang berbeza.

*Diagram 9.1 shows the positions P and Q at different altitude.*

Dua barometer ringkas yang serupa diletakkan pada kedua-dua kedudukan. Ketinggian turus merkuri ditunjukkan dalam Rajah 9.2.

*Two identical simple barometers are placed at both positions. The height of the mercury column in the barometers are shown in Diagram 9.2.*

Ketumpatan udara pada P ialah  $1.2 \text{ kgm}^{-3}$  dan ketumpatan udara pada Q ialah  $1.0 \text{ kg m}^{-3}$ .

*The density of air at P is  $1.2 \text{ kgm}^{-3}$  and the density of air at Q is  $1.0 \text{ kgm}^{-3}$*

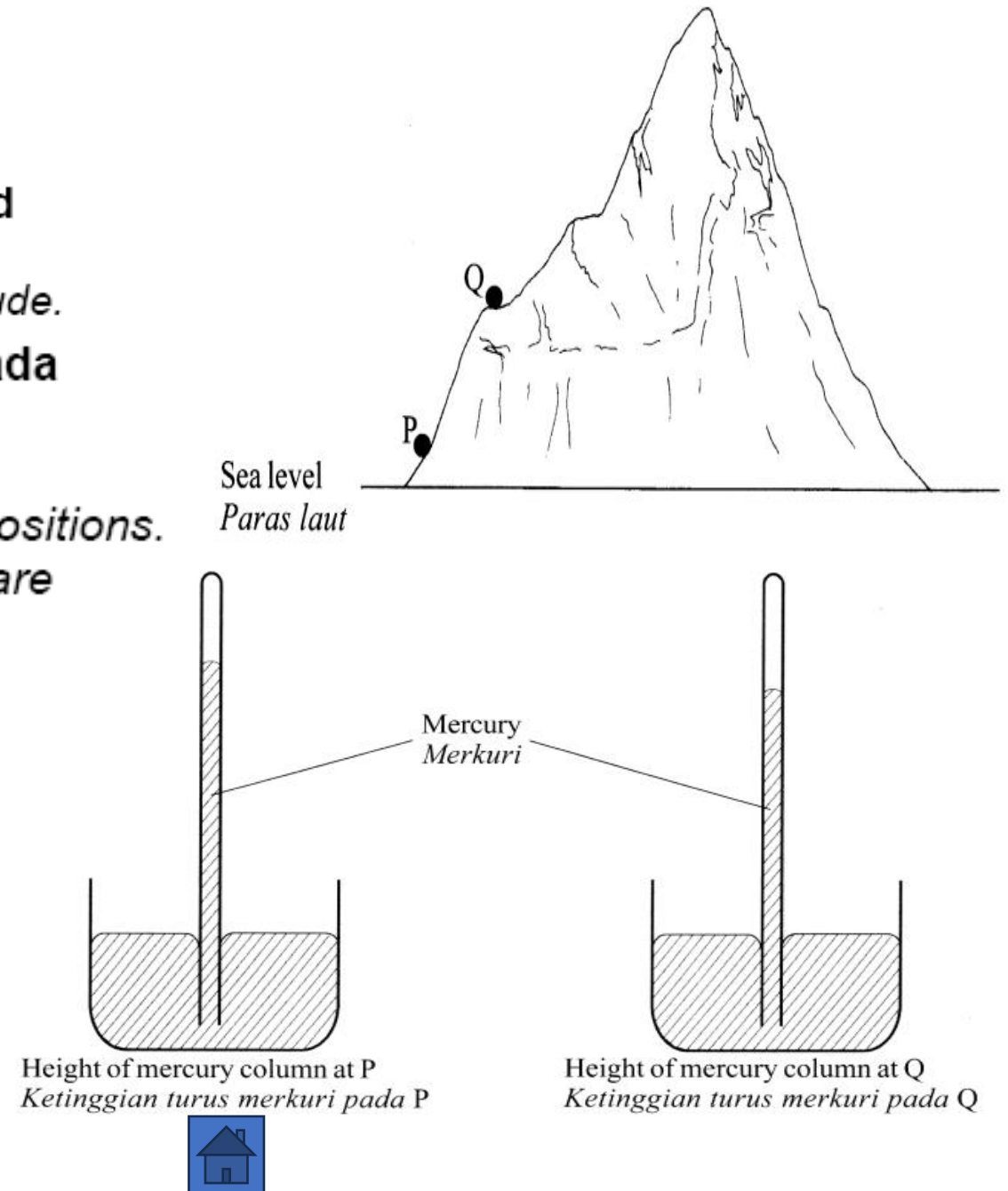

(a) Apakah maksud ketumpatan?  
*What is the meaning of density?*

[1 mark]

**Mass per volume /**  
**jisim per isipadu**

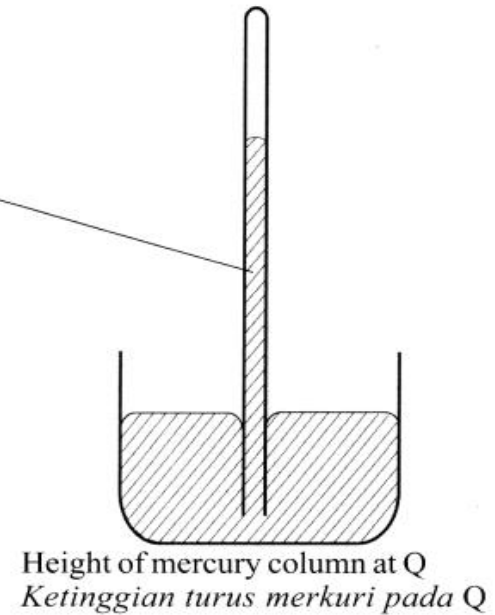
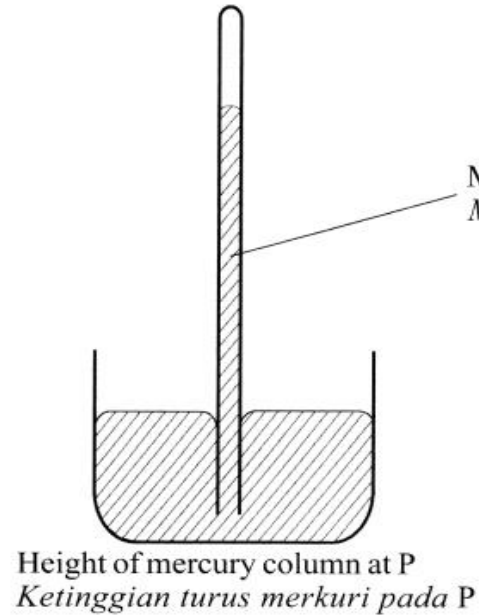
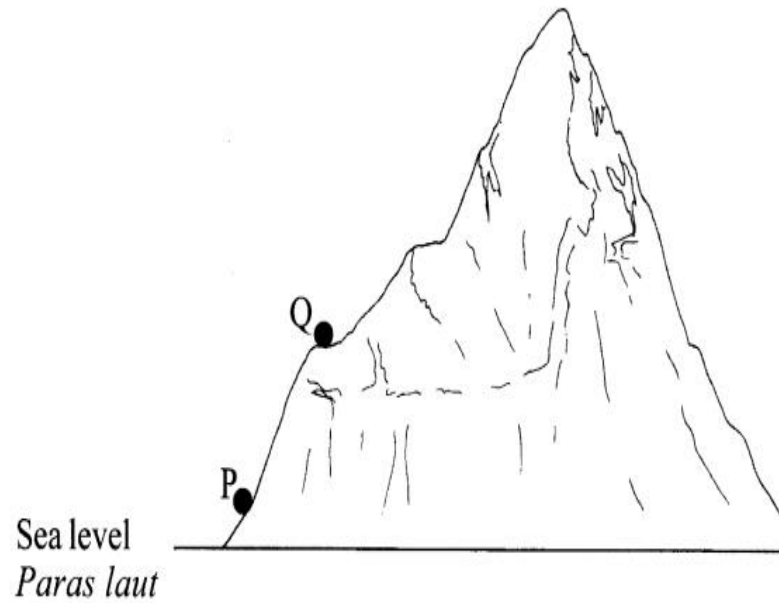

- (b) Menggunakan Rajah 9.1 dan Rajah 9.2, bandingkan altitud P dengan Q, ketumpatan udara di sekeliling dan ketinggian turus merkuri dalam barometer ringkas pada kedudukan P dan Q.  
*Using Diagram 9.1 and Diagram 9.2, compare the altitudes of P and Q, the density of surrounding air and the height of mercury column in the simple barometer at positions P and Q.*

[3 marks]

Ketumpatan udara pada P ialah  $1.2 \text{ kgm}^{-3}$  dan ketumpatan udara pada Q ialah  $1.0 \text{ kg m}^{-3}$ . *The density of air at P is  $1.2 \text{ kgm}^{-3}$  and the density of air at Q is  $1.0 \text{ kgm}^{-3}$*

**1. Altitude Q is higher / Q lebih tinggi**

**2. Density of air at Q is lower/  
ketumpatan udara Q rendah**

**3. Height of mercury column Q is lower  
turus merkuri Q lebih rendah**

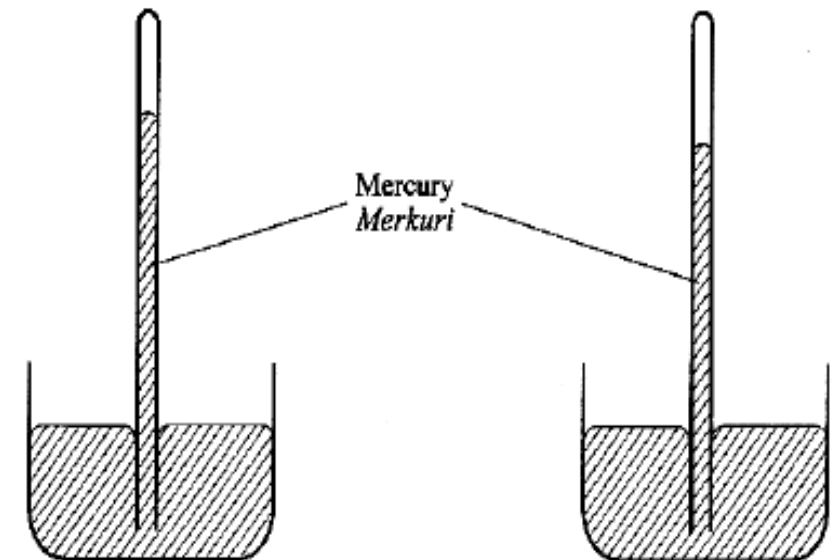
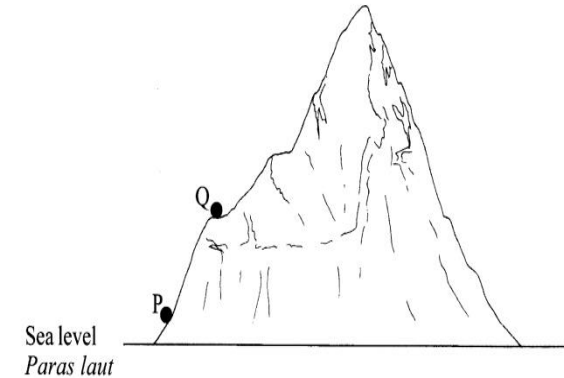

Height of mercury column at P  
*Ketinggian turus merkuri pada P*

Height of mercury column at Q  
*Ketinggian turus merkuri pada Q*

(c) Nyatakan hubungan antara altitud dengan  
*State the relationship between the altitude and*

(i) Ketumpatan udara  
*The density of the air*

(ii) Tekanan atmosfera  
*The atmospheric pressure*

[2 marks]

**The higher the altitude, the lower the density of air / semakin tinggi, semakin rendah ketumpatan udara**

**The higher the altitude, the lower the atmospheric pressure / semakin tinggi, semakin rendah tekanan atmosfera**

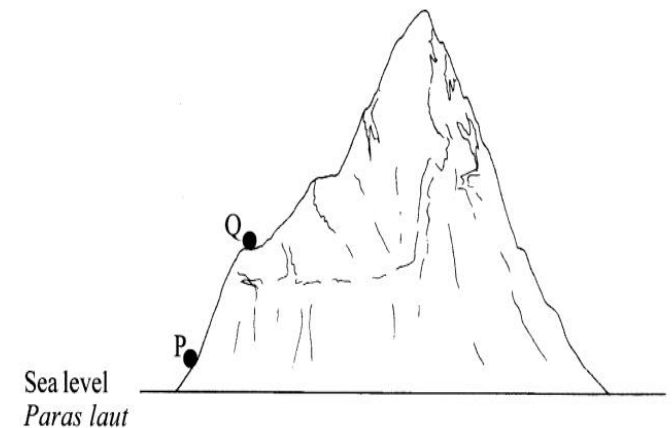

(d) Rajah 9.3 menunjukkan sebatang penitis dalam botol.

*Diagram 9.3 shows a dropper in a bottle.*

Menggunakan pengetahuan tentang tekanan atmosfera, terangkan bagaimana cecair di dalam botol disedut masuk ke dalam salur penitis tersebut.

*Using the knowledge of atmospheric pressure, explain how the liquid in the bottle can be sucked into the dropper tube.*

[4 marks]

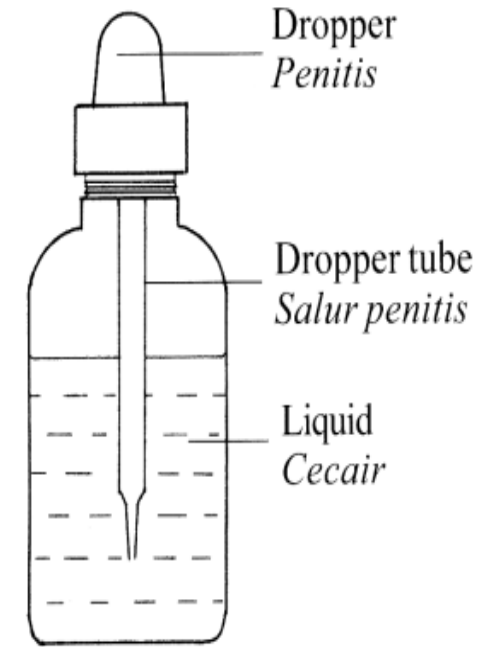

- 1. Press the dropper / tekan penitis**
- 2. Air inside the dropper is forced out / udara di dalam penitis dipaksa keluar**
- 3. Pressure inside decrease / tekanan di dalam berkurang**
- 4. Release the dropper/lepaskan penitis**
- 5. Atmospheric pressure push the liquid // difference in pressure / tekanan atmosfera menolak cecair // terdapat perbezaan tekanan**



- (e) **Diagram 9.4 shows a vacuum cleaner. Rajah 9.4 menunjukkan sebuah pembersih vakum.**

**You are required to give some suggestions to design a vacuum cleaner which can clean the dust faster and effectively. Using the knowledge on atmospheric pressure, Bernoulli's principle and properties of materials, explain your suggestion based on the following aspects:**

*Anda dikehendaki memberi beberapa cadangan untuk mereka bentuk sebuah pembersih vakum yang boleh membersihkan habuk dengan lebih cepat dan berkesan. Dengan menggunakan pengetahuan tentang tekanan atmosfera, prinsip Bernoulli dan ciri-ciri bahan, terangkan cadangan anda berdasarkan aspek-aspek berikut:*

- (i) **Material used for the body of vacuum cleaner.**  
*Bahan digunakan untuk badan pembersih vakum.*
- (ii) **Material used for the hose**  
*Bahan digunakan untuk hos*
- (iii) **The size of the fan**  
*Saiz kipas*
- (iv) **The size of the floor nozzle**  
*Saiz nozel lantai*
- (v) **The diameter of wand**  
*Diameter rod pemegang*

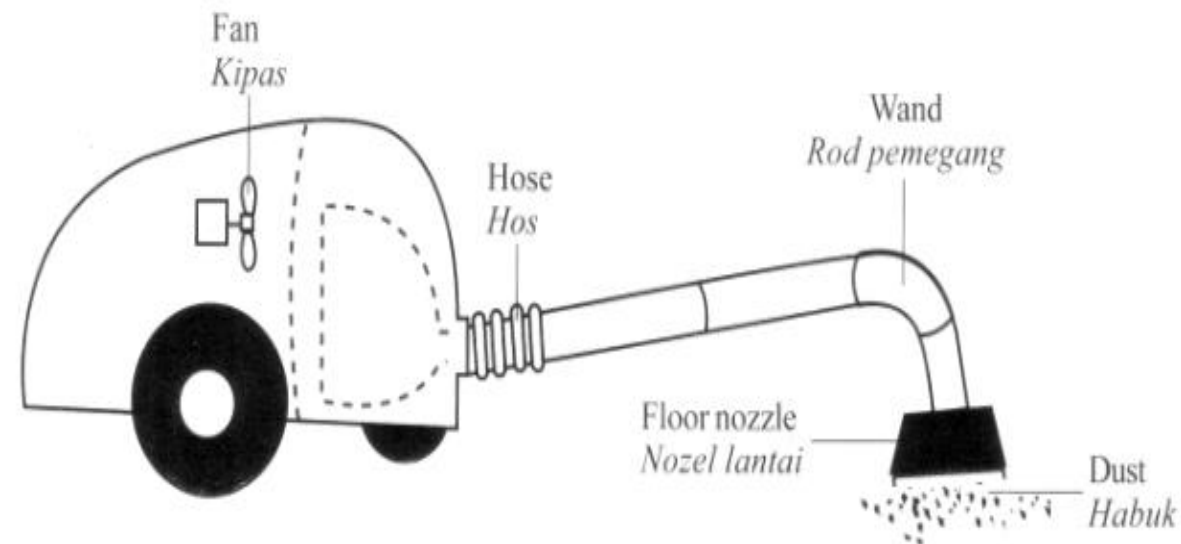

**[10 marks]**

<b>Material of body</b> <b>Bahan badan</b>	<b>Low density/ Strong / plastic / ketumpatan rendah / kuat / plastik</b>	<b>Lighter / Not easily break</b> <b>Ringan / tidak mudah pecah</b>
<b>Material of the hose</b> <b>Bahan hos</b>	<b>Flexible / elastic</b> <b>Strong / kenyal / kuat</b>	<b>Easy to adjust / Does not tear</b> <b>Twist/ moveable / tidak koyak / mudah bergerak</b>
<b>Size of fan</b> <b>Saiz kipas</b>	<b>Bigger fan / kipas besar</b>	<b>More air can be sucked / lower pressure inside / sedut banyak udara keluar / tekanan rendah di dalam</b>
<b>Floor nozzle size</b> <b>Saiz nozzle lantai</b>	<b>Wider floor nozzle</b> <b>Nozle lantai yang luas</b>	<b>More dust is sucked</b> <b>Boleh sedut banyak habuk</b>
<b>Diameter of the wand / diameter rod pemegang</b>	<b>Small diameter</b> <b>Diameter kecil</b> 	<b>Lower pressure / high velocity</b> <b>Laju tinggi / tekanan rendah</b>

## Section C - 2005

- (a) A fisherman finds that his boat is at different levels in the sea and in the river, although the boat carries the same load. The density of sea water is  $1\,025\text{ kg m}^{-3}$  and of river water is  $1\,000\text{ kg m}^{-3}$ . Figure 9.1 and Figure 9.2 illustrate the situation of the boat in the sea and in the river.

*Seorang nelayan mendapati botnya pada aras yang berbeza semasa di laut dan di sungai, walaupun bot itu membawa muatan yang sama. Ketumpatan air laut ialah  $1025\text{ kg m}^{-3}$  dan ketumpatan air sungai ialah  $1000\text{ kg m}^{-3}$ . Rajah 9.1 dan 9.2 menggambarkan situasi bot itu ketika di laut dan di sungai.*



Sea / Laut

Figure 9.1



River / Sungai

Figure 9.2

- (i) What is meant by density?  
*Apakah maksud ketumpatan?* [1 mark]

**Ketumpat = jisim/ isipadu**

***Density = mass / volume***

- (ii) Using Figure (a) and Figure (b), compare the levels of the boat and the volumes of water displaced by the boat.

Relating the mass of the boat with its load, the volume of water displaced and the density of the water deduce a relevant physics concept.

*Menggunakan Rajah 9.1 dan Rajah 9.2, bandingkan aras bot dan isi padu air yang disesarkan dan ketumpatan itu, untuk menyimpulkan satu konsep fizik yang sesuai.*

[5 marks]

- (iii) Name the physics principle that explains the above situations.

*Namakan prinsip fizik yang menerangkan situasi di atas.*



[1 marks]

**Aras bot: air sungai > air laut**

**Level of boat: river water > sea water**

**Isipadu air disesarkan: air sungai > air laut**

**Volume of water displaced: river water > sea water**

**Ketumpatan: air sungai < air laut**

**Density: river water < sea water**

**Bot terapung kerana diimbangi dengan daya apungan**

**The boat floats because it is being balanced by the buoyant force**

**Berat bot dan muatan: air sungai = air laut**

**Weight of boat + load: river water = sea water**

**Daya apungan: air sungai = air laut**

**Buoyant force: river water = sea water**

**Semakin kecil ketumpatan, semakin besar isipadu air disesarkan**

**The lower the density, more water will be displaced**



Sea / Laut

Figure 9.1



River / Sungai

Figure 9.2



(iii) Name the physics principle that explains the above situations.

*Namakan prinsip fizik yang menerangkan situasi di atas.*

[1 marks]

(b) A submarine can sail on the sea surface and under the sea. Explain how a submarine on the surface submerges.

*Suatu kapal selam boleh berlayar di permukaan laut dan di dalam laut. Terangkan cara bagaimana suatu kapal selam yang berada di permukaan laut tenggelam ke dalam laut.*

[4 marks]

**Kapal selam mempunyai tangki balast**  
**The submarine has a ballast tank**

**Air diisi ke dalam tangki ballast untuk meningkatkan berat kapal selam**  
**Water is filled in the ballast tank to increase the weight of the submarine.**

## **Prinsip Archimedes**

### **Archimedes principle**

**Kapal selam tenggelam ke dalam air apabila beratnya lebih dari daya apungan.**  
**The submarine sinks into the water when its weight is larger than buoyant force**



(c) Figure 9.3 and Figure 9.4 illustrate the working principle of a hydrometer. The depth to which the test tube sinks depends on its surrounding liquid.

*Rajah 9.3 menggambarkan prinsip kerja hydrometer. Kedalaman tabung uji itu tenggelam bergantung kepada ketumpatan cecair di sekitarnya.*

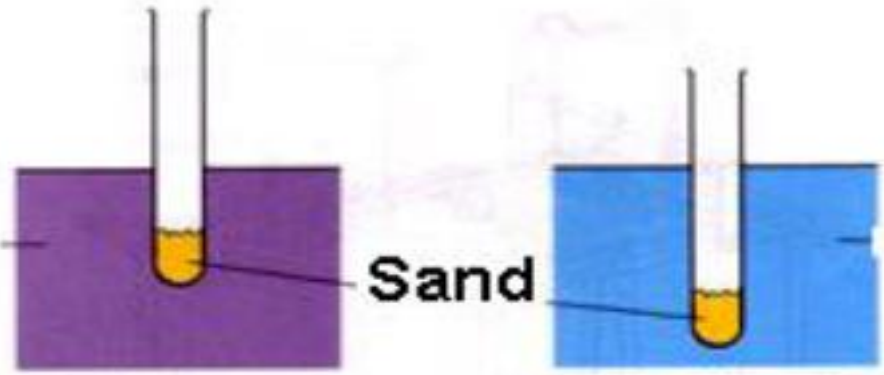

**Water**  
Figure 9.3

**Alcohol**  
Figure 9.4

Explain how you would design a hydrometer that can determine a wide range of densities of liquid, using the idea of the working principle of a hydrometer shown above.

Draw a diagram that shows the design of your hydrometer and in your explanation, emphasize the following aspects:

*Terangkan bagaimana anda merekabentuk satu hydrometer yang boleh menentukan ketumpatan cecair dalam julat yang besar, dengan menggunakan idea tentang prinsip kerja hydrometer yang ditunjukkan di atas. Lukiskan rajah yang menunjukkan reka bentuk hydrometer anda dan dalam penerangan ands berikan penekanan bagi aspek-aspek berikut:*

- (i) the stability of the hydrometer  
*kestabilan hydrometer*
- (ii) the sensitivity of the hydrometer  
*kepekaan hydrometer itu*
- (iii) the ability to measure a wide range of densities of liquids  
*kebolehan menentukan ketumpatan cecair dalam julat yang besar.*
- (iv) the calibration of the hydrometer  
*penentukuran hydrometer itu.*



[10 marks]

**Letakkan bola plumbum ke dalam bebuli kaca / Put in some plumbum ball in the glass bulb**

**Pastikan hydrometer tegak  
To ensure the hydrometer is upright**

**Batang yang halus  
Using a small stem**

**Dapatkan julat skala yang lebih besar  
To have a bigger interval of the scale**

**Guna bebuli kaca besar  
Using a big bulb**

**Daya apungan besar  
High buoyant force**

**Batang hydrometer  
Panjang / Long stem**

**Hidrometer tidak tenggelam sepenuhnya dalam cecair ketumpatan rendah  
The hydrometer does not sink fully in low density liquid**

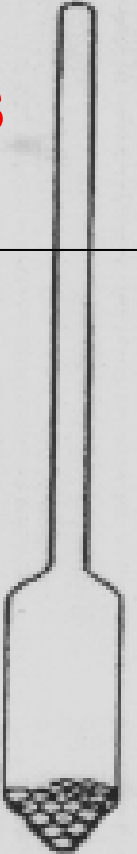

Terapungkan hydrometer dalam minyak paraffin / alcohol. Aras cecair pada batang = ketumpatan minyak paraffin /alkohol

*Float the hydrometer into a paraffin oil / alcohol. The liquid level at the stem = to the density of paraffin oil / alcohol*

Terapungkan hydrometer ke dalam air laut. Aras cecair pada batang = ketumpatan air laut

*Floats the hydrometer into a sea water. The liquid level at the stem = density of sea water*

Skalakan batang menggunakan aras atas dan aras bawah ketumpatan

*Scale the stem using the upper and the lower level of density*



## Section C - 2010

### Section B: Question 9

Rajah 9.1 menunjukkan seorang budak lelaki dan bapanya, masing-masing duduk di atas dua bola pantai, A dan B, yang serupa.

*Diagram 9.1 shows a boy and his father sitting on two identical beach balls, A and B, respectively.*

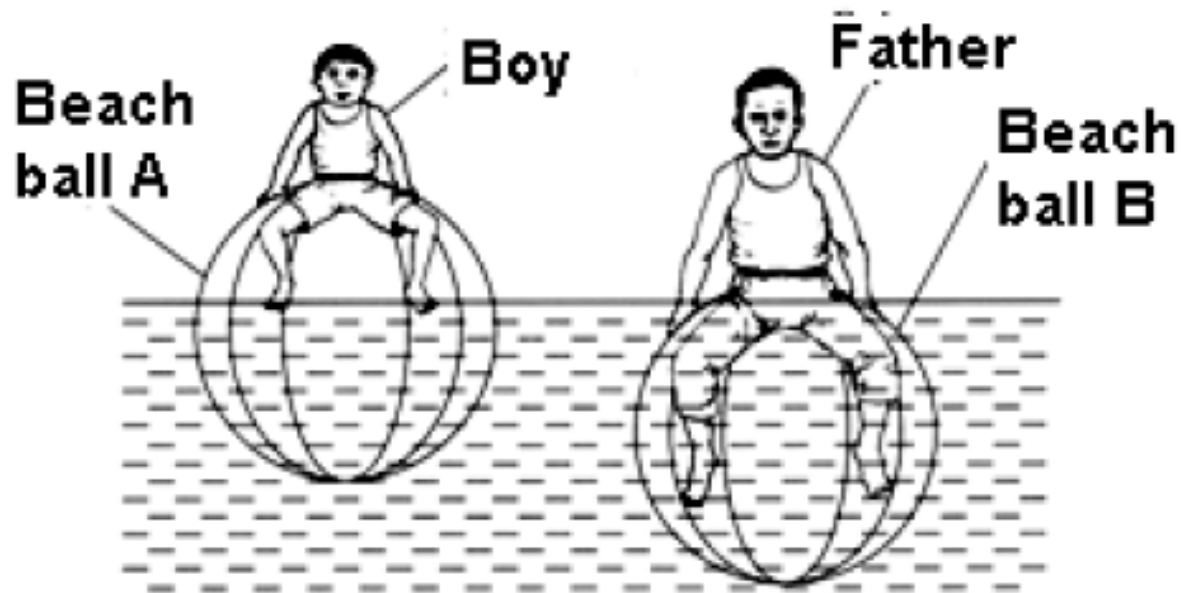

**Berat mereka diseimbangkan oleh daya apung.**  
*Their weights are balanced by the buoyant force.*

- (a) **Apakah maksud berat?**  
*What is the meaning of weight?*

[1 mark]

**Gravitational force acts on an object**

**Daya tarikan yang bertindak ke atas objek**



**The weight of the father is higher**  
**Berat ayah lebih besar**

**Volume of water displaced: ball B > ball A**  
**Isipadu air disesarkan**

**Buoyant force: father > boy**  
**Daya apungan**

**Volume of water displaced is directly proportional to buoyant force**  
**Isipadu air disesarkan berkadar terus dengan daya apungan**

**Weight of water displaced = buoyant force**  
**Berat air disesarkan = daya apungan**

(b) (i) Menggunakan Rajah 9.1, bandingkan berat budak lelaki itu dengan bapanya, isipadu air yang disesarkan dan daya apung yang bertindak ke atas kedua-dua mereka.

*Using Diagram 9.1, compare the weight of the boy and his father, the volume of the water displaced and the buoyant force acted on both of them.*

[3 marks]

(ii) Nyatakan hubungan antara daya apung dengan:

*State the relationship between the buoyant force and:*

- Isipadu air yang disesarkan  
*The volume of water displaced*
- Berat air yang disesarkan.  
*The weight of water displaced*

[2 marks]

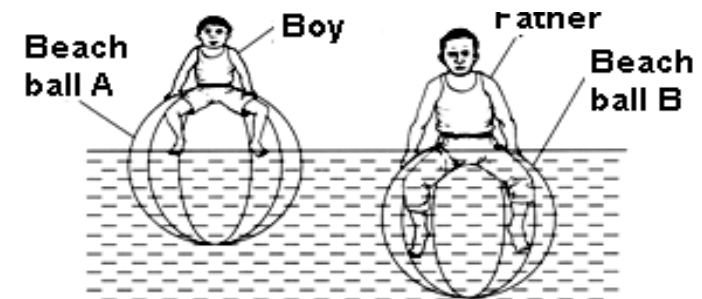

(iii) Namakan prinsip fizik yang terlibat.  
*Name the physics principle involved.*  
[1 mark]

(c) Rajah 9.2 menunjukkan apa yang berlaku apabila sebuah blok kayu dipegang di atas permukaan air dan kemudian dilepaskan ke dalam air.

*Diagram 9.2 shows what happens when a wooden block is held above the water surface and then released into the water.*

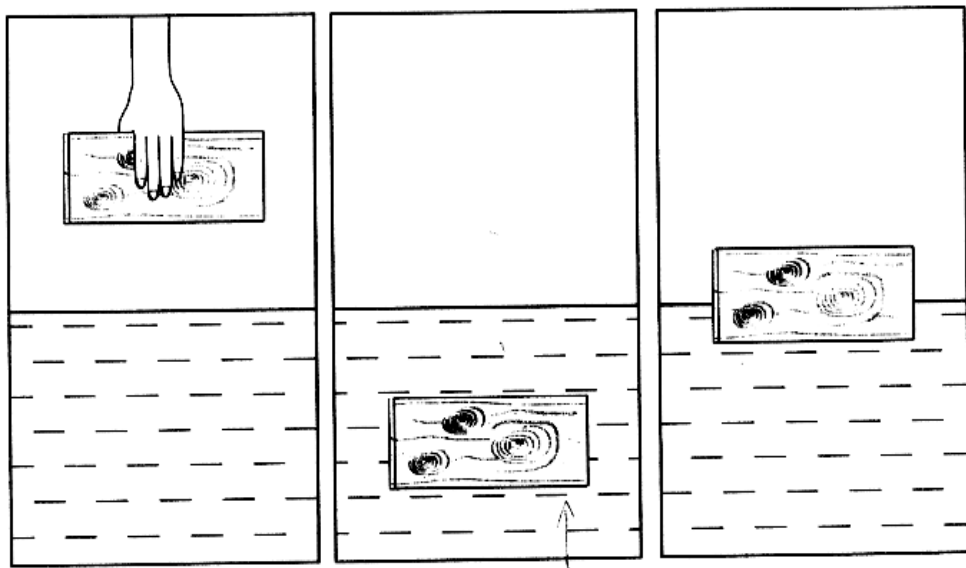

## Archimedes' principle

### Prinsip Archimedes

Apabila blok kayu dilepaskan, blok itu jatuh ke dalam air dan tenggelam sepenuhnya di bawah permukaan air. Kemudian blok itu bergerak ke atas dan terapung pada permukaan air. Dengan menggunakan konsep daya apung, terangkan mengapa blok kayu itu bergerak ke atas dan kemudian terapung pada permukaan air..

*When the wooden block is released, it falls into the water and goes completely under the water surface. Then it moves upwards and floats on the water surface.*

*Using the concept of buoyant force, explain why the wooden block moves upwards and then floats on the water surface.*



[3 marks]

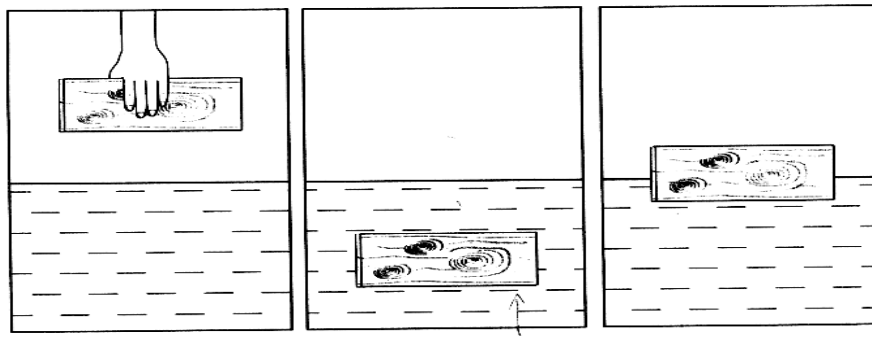

**1<sup>st</sup> : Buoyant increases when the volume of the immersed wooden block increases.**

**2<sup>nd</sup> : buoyant force is larger than the weight when the wooden block is moving upwards.**

**3<sup>rd</sup> : Buoyant force equals to weight of the wooden block when it is floating on the surface of water.**

**1<sup>st</sup> : Daya apung bertambah apabila isipadu blok kayu yang terendam dalam air bertambah**  
**2<sup>nd</sup> : daya apung bergerak lebih besar daripada berat apabila bongkah kayu bergerak ke atas**  
**3<sup>rd</sup> : daya apung sama dengan berat bongkah kayu terapung atas permukaan air.**



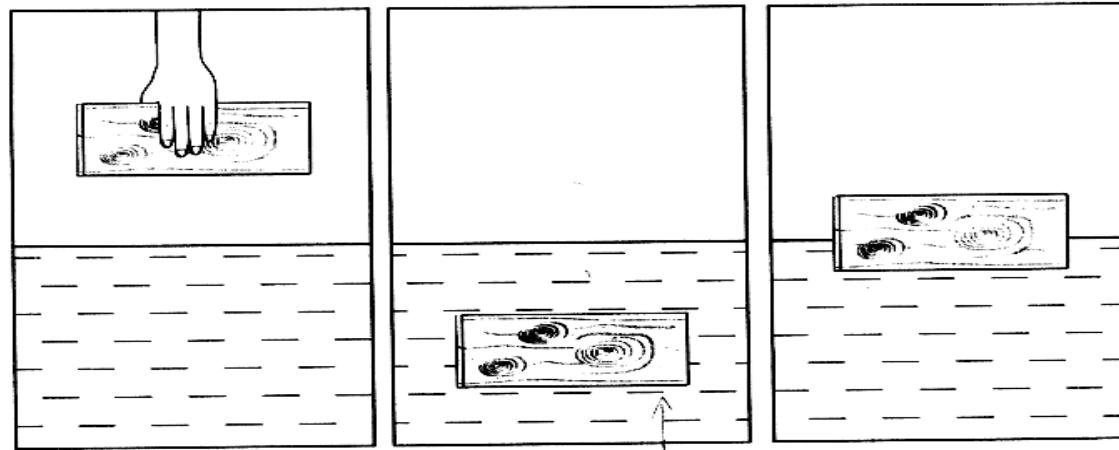

**1<sup>st</sup> : Daya apung bertambah apabila isipadu blok kayu yang terendam dalam air bertambah**

**2<sup>nd</sup> : daya apung bergerak lebih besar daripada berat apabila bongkah kayu bergerak ke atas**

**3<sup>rd</sup> : daya apung sama dengan berat bongkah kayu terapung atas permukaan air.**



(d) The State Forestry Department is going to organize a raft competition. As a team leader, you are required to give some suggestions to design a raft which can accommodate 15 participants and be able to move quickly in water.

Using your knowledge of motion, forces and properties of materials, state and explain the suggestions, based on the following aspects:

*Jabatan Perhutanan Negeri akan menganjurkan pertandingan berakit. Sebagai ketua pasukan, anda dikehendaki memberikan cadangan dalam mereka bentuk sebuah rakit yang boleh membawa 15 peserta dan berupaya untuk bergerak dengan laju dalam air. Menggunakan pengetahuan anda dalam gerakan, daya-daya dan sifat bahan, nyatakan dan terangkan cadangan itu, berdasarkan aspek-aspek berikut:*

- (i) The shape of the raft  
*Bentuk rakit* [2 marks]
- (ii) The material used for the raft  
*Bahan digunakan untuk rakit* [2 marks]
- (iii) The size of the raft  
*Saiz rakit.* [2 marks]
- (iv) The design of the raft.  
*Reka bentuk rakit* [4 marks]



<b>Modificationr</b>	<b>Reason</b>
<b>Bentuk larus / Streamline shape</b>	<b>Kurang rintangan air / less water resistance</b>
<b>Bahan ketumpatan rendah / low density material</b>	<b>Boleh terapung dengan mudah Easy to float</b>
<b>Saiz besar / Big size</b>	<b>Boleh menampung ramai peserta / can accommodate more participants</b>
<b>Beberapa lapis / A few layers</b>	<b>Menyesarkan lebih air/ daya apungan tinggi / high buoyant force</b>
<b>Pasang botol plastik/attach plastic bottle / polisterene /</b>	<b>Menambahkan daya tujah High thrust force</b>
<b>Tambah layar/ pengayuh/ kipas /motor / Add sail / paddle / fan</b>	<b>Halaju tambah Increase speed</b>



## Section C - 2016

Diagram 9.1 shows a hot-air balloon floating stationary in the air during afternoon. Diagram 9.2 shows the position of the same hot air balloon floating stationary in the air during early morning.

Rajah 9.1 menunjukkan sebiji belon udara panas terapung pegun di udara pada waktu tengah hari. Rajah 9.2 menunjukkan kedudukan belon udara panas yang sama terapung pegun di udara ketika awal pagi.

(a) (i) What is the meaning of density?

Apakah yang dimaksudkan dengan ketumpatan?

**Mass per unit volume**  
**jisim per unit isipadu**

[1 mark]

Afternoon  
*Tengah hari*

Density of air  
outside the balloon =  $1.083 \text{ kg m}^{-3}$   
*Ketumpatan udara*  
*di luar belon*

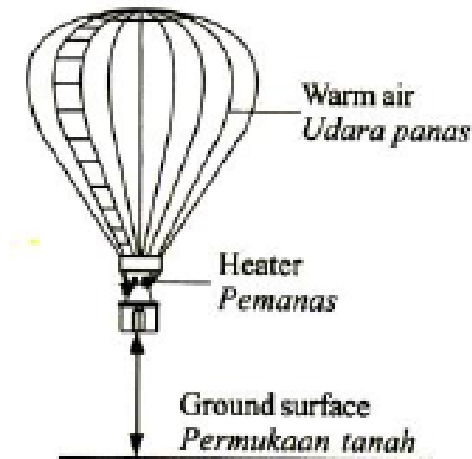

Diagram 9.1  
*Rajah 9.1*

Early morning  
*Awal pagi*

Density of air  
outside the balloon =  $1.124 \text{ kg m}^{-3}$   
*Ketumpatan udara*  
*di luar belon*

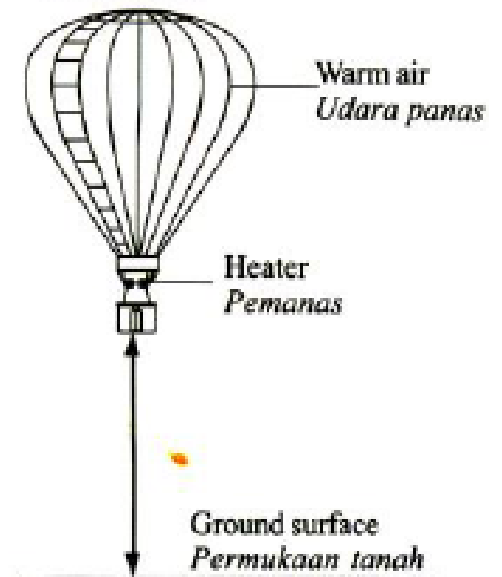

Diagram 9.2  
*Rajah 9.2*



Afternoon  
Tengah hari

Density of air  
outside the balloon =  $1.083 \text{ kg m}^{-3}$   
Ketumpatan udara  
di luar belon



Diagram 9.1

Early morning  
Awal pagi

Density of air  
outside the balloon =  $1.124 \text{ kg m}^{-3}$   
Ketumpatan udara  
di luar belon

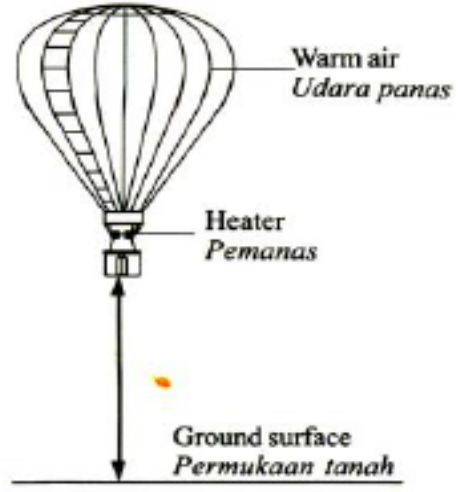

Diagram 9.2

(ii) Observe Diagram 9.1 and Diagram 9.2. Compare the height of the balloon, the density of the air and the temperature of the air outside the balloon. Relate the temperature of the air with the density of the air outside the balloon to make a deduction on the relationship between the buoyant force and the temperature.  
Perhatikan Rajah 9.1 dan Rajah 9.2. Bandingkan ketinggian belon, ketumpatan udara dan suhu udara di luar belon. Hubungkan suhu udara dengan ketumpatan udara di luar belon untuk membuat deduksi tentang hubungan antara daya apungan dengan suhu.

- Height of 9.2 is higher / ketinggian 9.2 lebih tinggi
- Density of air 9.2 is higher / ketumpatan udara 9.2 lebih tinggi
- Temperature of air 9.2 is lower / suhu udara 9.2 lebih rendah
- Higher temperature, lower density of air / suhu udara di luar belon 9.2 lebih rendah
- Higher temperature, the lower the buoyant force / suhu bertambah tinggi, daya apungan semakin rendah



[5 marks]

- (b) **Diagram 9.3 shows a boy is holding balloon filled with gas.**  
*Rajah 9.3 menunjukkan seorang budak lelaki sedang memegang belon berisi gas.*

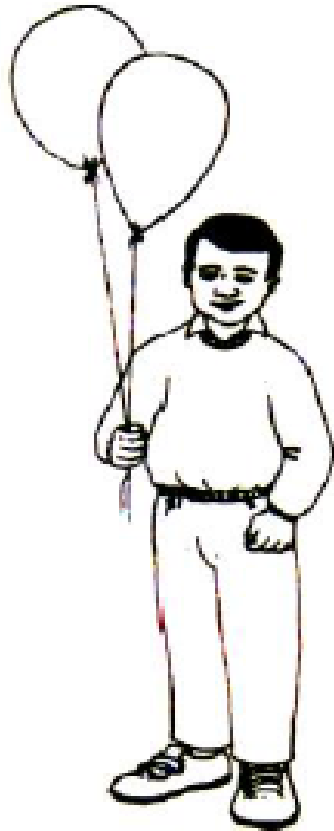

**Diagram 9.3**

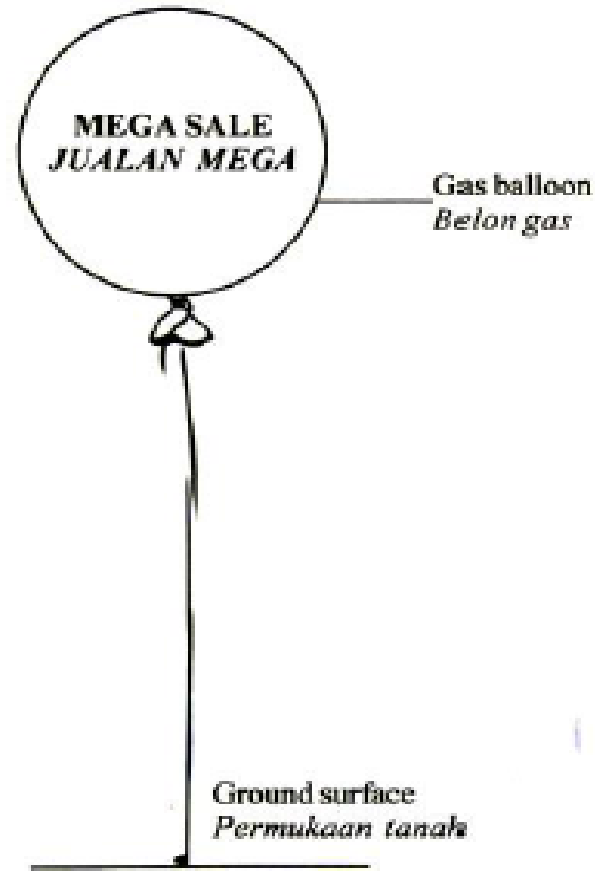

**Diagram 9.4**

**Explain why the balloons rise up when the boy releases them.**

*Terangkan mengapa belon-belon itu naik ke atas apabila budak itu melepaskannya.*

**[4 marks]**



- **Density of gas low// ketumpatan gas rendah**
- **Weight balloon low / lighter / berat belon rendah**
- **Buoyant force = volume of air displaced x density of air x gravitational acceleration /  $F = \rho v g$  /buoyant force is directly proportional to density of air/ buoyant force = weight of air displaced**  
**daya apung = (isipadu udara disesarkan) x (ketumpatan udara) x pecutan gravity / daya apung berkadar terus dengan ketumpatan udara / daya apung = berat udara disesarkan**
- **Buoyant force > weight of balloon / daya apung > jumlah berat belon**



- (c) Diagram 9.4 shows a gas balloon used for an advertisement. Suggest and explain how to produce a balloon that is able to float for a few days effectively, based on the the following aspects:

*Rajah 9.4 menunjukkan sebiji belon gas digunakan untuk pengiklanan. Cadang dan terangkan bagaimana untuk menghasilkan belon yang dapat terapung beberapa hari dengan efektif berdasarkan aspek-aspek berikut:*

- (i) **The gas used in the balloon**

*Gas yang digunakan dalam belon,*

- (ii) **The material used for the balloon**

*Bahan yang digunakan dalam belon*

- (iii) **The size of the balloon**

*Saiz belon*

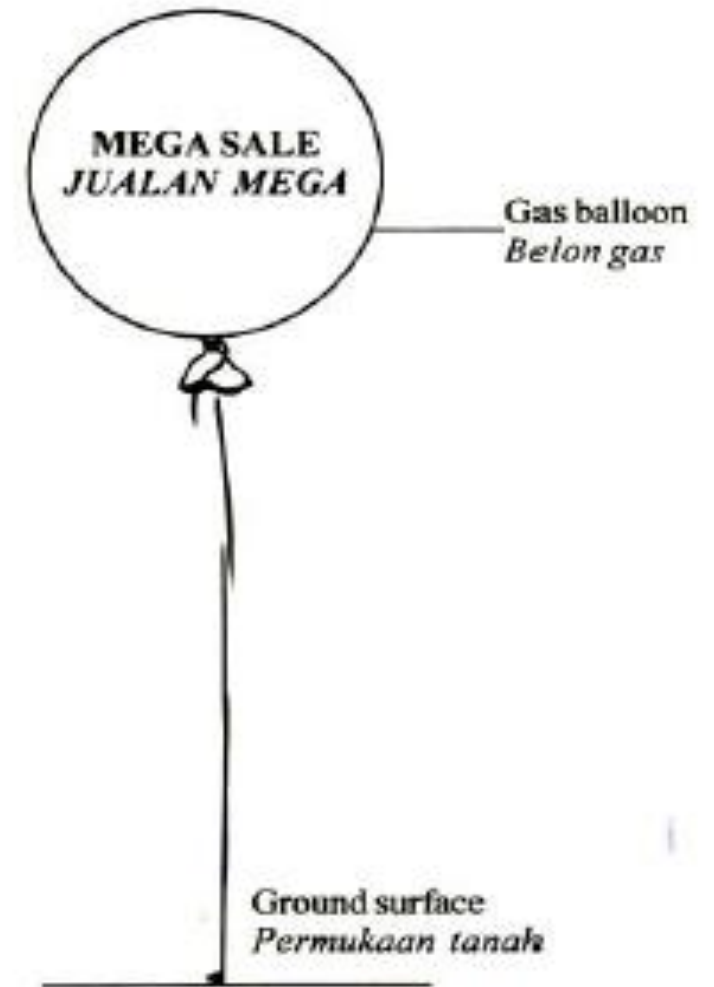

**Diagram 9.4**



Characteristics	reason
<b>Helium / hidrogen</b>	<b>Low density / light/ ketumpatan rendah/ ringan</b>
<b>Low density / light/ ketumpatan rendah/ ringan</b>	<b>Light / ringan</b>
<b>Elastic / strong / kenyal / kuat</b>	<b>Withstand pressure/ not burst/ lasting/ durable// tahan lama / tahan lasak / tidak bocor</b>
<b>Low density / ketumpatan rendah</b>	<b>Light / ringan</b>
<b>Water proof/ air proof// kalis air / kalis udara</b>	<b>Gas not loss// elak resapan</b>
<b>nylon</b>	<b>elastic/light/ strong kenyal / ringan/tahan koyak/ kuat</b>
<b>Large size/ saiz besar</b>	 <b>Large air displaced/large buoyant force / daya apung lebih besar / isipadu udara sesar lebih besar</b>

## Section C - 2007

9(a) Rajah 9.1 menunjukkan suatu keratan rentas bagi sayap sebuah kapal terbang yang sedang bergerak. Sayap kapal terbang itu mengalami daya angkat.

*Diagram 9.1 shows a cross section of a wing of a moving aeroplane. The wing of the aeroplane experiences a lift force.*

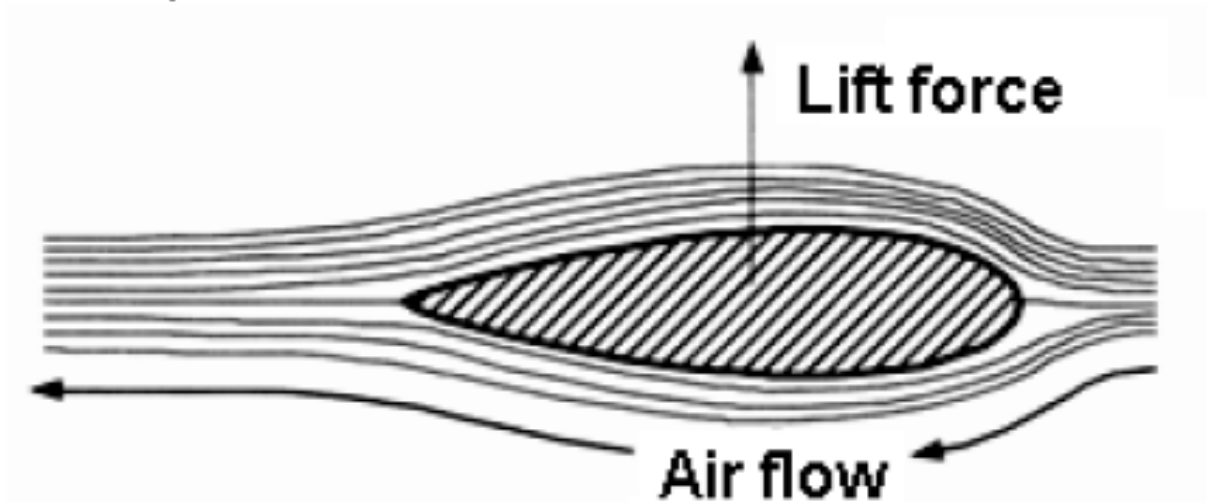

(i) Namakan bentuk keratan rentas dalam Rajah 9.1.

*Name the shape of the cross-section in Diagram 9.1.*

**Aerofoil**



(ii) Terangkan mengapa daya angkat bertindak pada sayap kapal terbang itu.

*Explain why the lift force acts on the wing of the aeroplane.*

[3 marks]

**Higher velocity on the upper surface**  
**halaju tinggi di bahagian atas**

**Lower pressure on the upper surface**  
**tekanan rendah di bahagian bawah**

**Higher pressure on the bottom surface / difference in pressure**  
**tekanan tinggi di bawah / perbezaan tekanan**

**Lift force = difference in pressure x area of surface**

**Daya angkat = perbezaan tekanan x luas permukaan**

**Produce lift force / daya angkat terhasil**

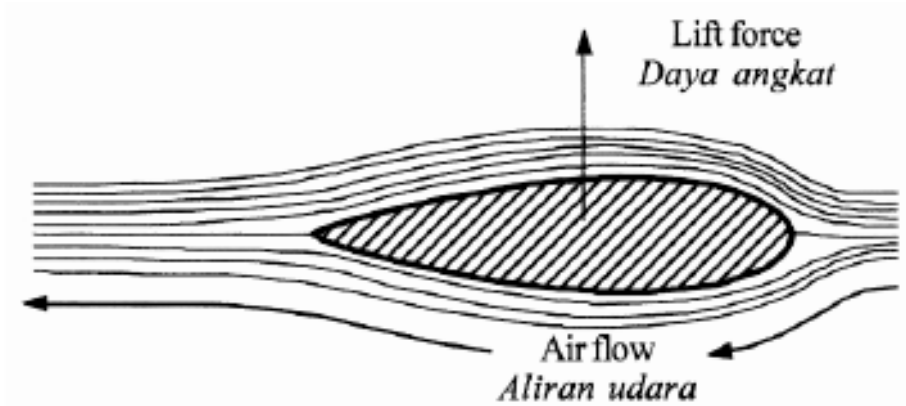

(b) Dua orang peluncur ski berlepas dengan halaju yang sama ketika menuruni satu platform yang tinggi. Rajah 9.2 dan Rajah 9.3 menunjukkan keadaan badan bagi dua orang peluncur ski itu semasa berlepas dari platform. Rajah 9.4 dan Rajah 9.5 menunjukkan keadaan badan dua peluncur ski itu semasa di udara. Kedua-dua peluncur itu mendarat di permukaan tanah pada ketika yang sama.

*Two ski jumpers ski down from a very high platform with the same take off velocity. Diagram 9.2 and Diagram 9.3 show the posture of the two ski jumpers during take off from the platform. Diagram 9.4 and Diagram 9.5 show the posture of the two ski jumpers in the air. They land on the ground at the same instant.*

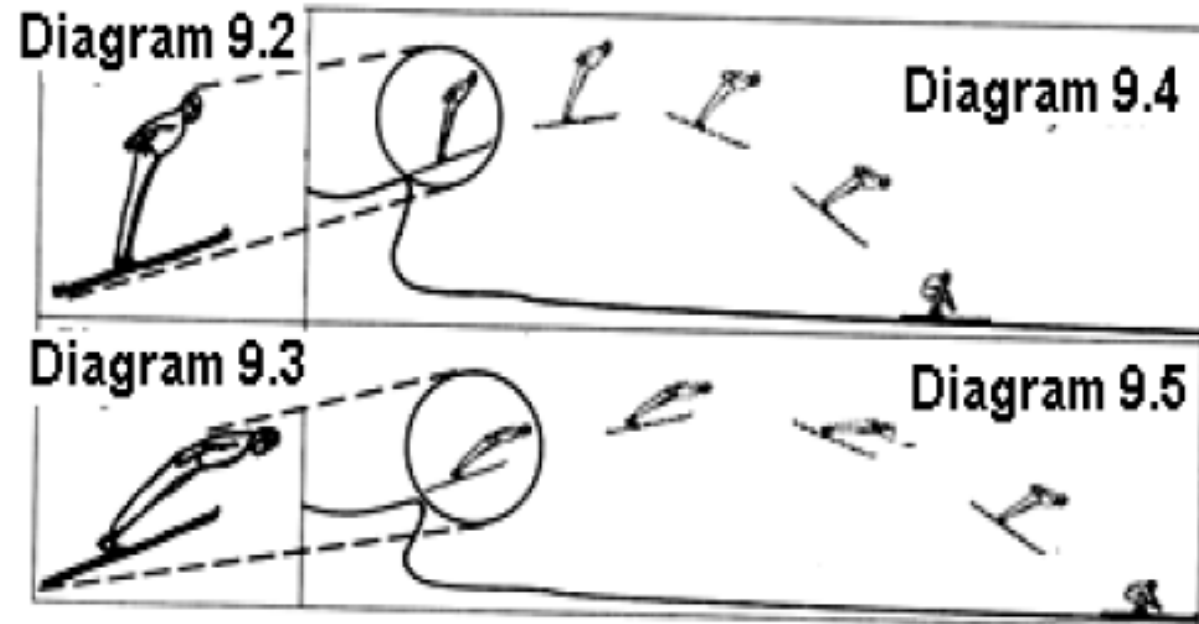

**Berdasarkan Rajah 9.2 dan Rajah 9.3, bandingkan keadaan badan kedua-dua peluncur ski itu.**

*Based on Diagram 9.2 and Diagram 9.3, compare the posture of the two ski jumpers. [1 mark]*

**Berdasarkan Rajah 9.4 dan 9.5, bandingkan jarak mendarat bagi kedua-dua peluncur ski itu.**

*Based on Diagram 9.4 and Diagram 9.5, compare the landing distance of the two ski jumpers. [1 mark]*

**9.2 : less bending / kurang bengkok**  
**9.3: more bending / lebih bengkok**

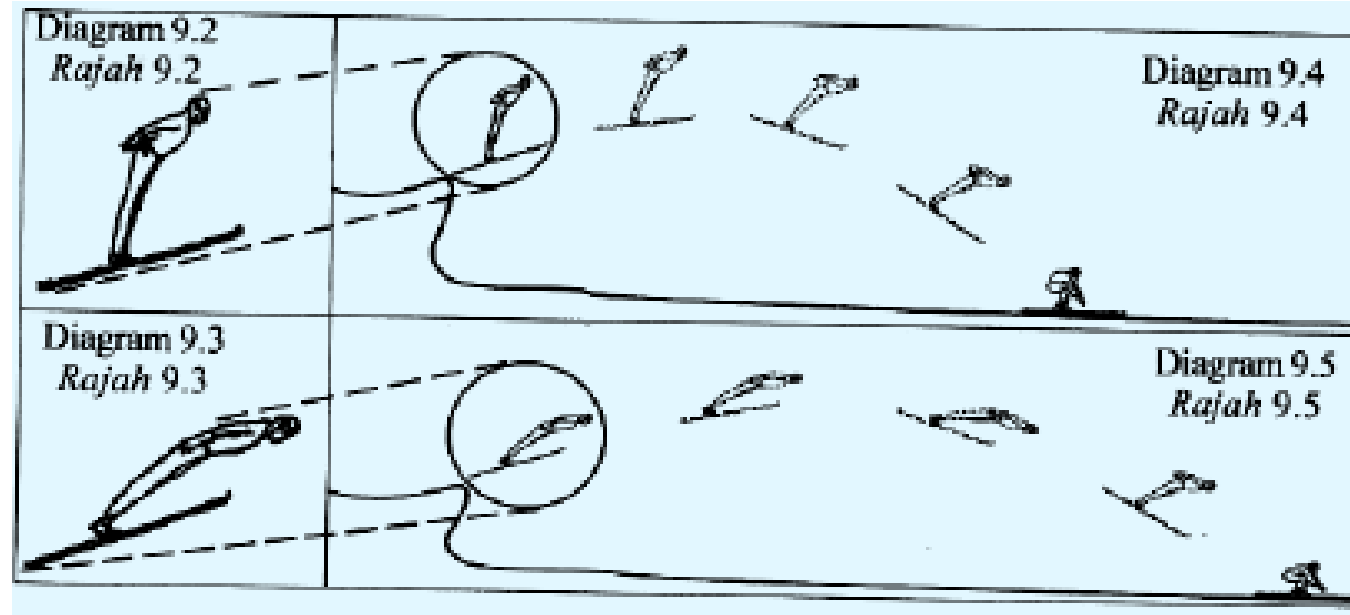

**9.3 : further // longer landing distance / jarak mendarat jauh**  
**9.2: shorter (landing distance) / jarak mendarat dekat**



- (iii) Merujuk kepada Rajah 9.4 dan Raah 9.5, hubungkaitkan antara daya angkat dengan jarak mendarat.  
*Based on Diagram 9.4 and Diagram 9.5, relate the lift force to the landing distance.*

The higher the lift force, the further the landing distance  
**Semakin jauh jarak mendarat, semakin besar daya angkat**

Namakan satu sukan yang menggunakan prinsip daya angkat yang sama dengan peluncur ski itu. Jelaskan persamaan itu.

*Name one sport which uses the same principle of lift force as the ski jumper. Explain the similarities.*

[2 marks]

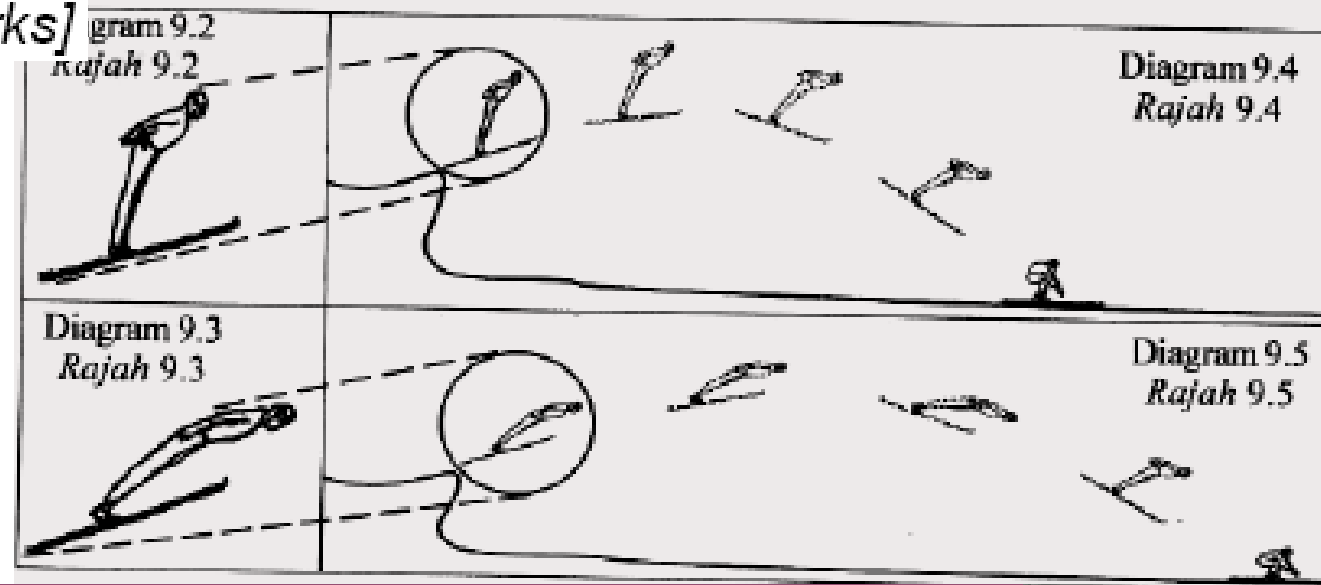

[2 marks]

- Long jump // triple jump // glider / **lompat jauh / lompat kijang**
- the lift force is directly proportional to landing distance / **daya angkat berkadar terus dengan jarak mendarat**



- (c) **Rajah 9.6 menunjukkan sebuah perahu layar.**  
*Diagram 9.6 shows a sailboat.*

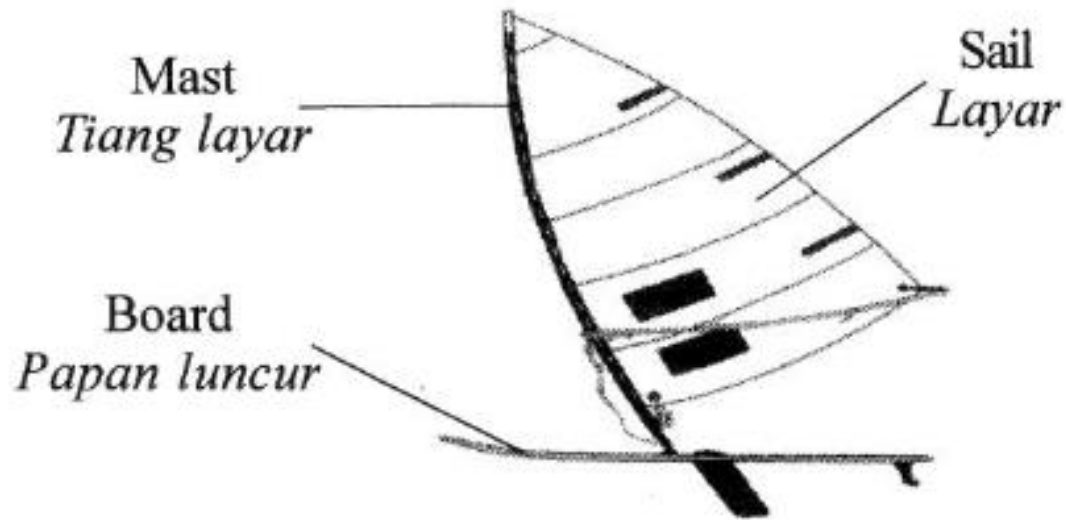

**You are required to give some suggestions to design a sailboat which can travel faster. Using the knowledge on motion, forces and the properties of materials, explain the suggestions based on the following aspect:**  
*Anda dikehendaki memberi beberapa cadangan untuk mereka bentuk sebuah perahu layar yang boleh bergerak dengan lebih laju. Menggunakan pengetahuan tentang gerakan, daya dan sifat-sifat bahan, terangkan cadangan anda berdasarkan aspek-aspek berikut:*

- (i) **the surface of the board**  
*permukaan papan luncur*
- (ii) **the shape of the board**  
*bentuk papan luncur*
- (iii) **material used for the board**  
*bahan digunakan untuk papan luncur*
- (iv) **material used for the sail**  
*bahan digunakan untuk layar*
- (v) **the size of the sail**  
*saiz layar*



**[10 marks]**

<b>Modification</b>	<b>Reason</b>
<b>1. Smooth board //coat with wax / papan luncur licin</b>	<b>2. Reduce friction / kurang rintangan</b>
<b>3. Stream line / bentuk lurus</b>	<b>4. Reduce resistance / kurang rintangan</b>
<b>5. Low density material // strong material // carbon composite // fiber glass // bahan ketumpatan rendah / bahan kuat / komposit karbon / gentian kaca</b>	<b>6. Easy to float // not easy to break // slides faster // increase the speed // light // withstand high force of wave. / mudah terapung / tidak mudah pecah / luncur laju / laju bertambah / ringan / tahan daya yang tinggi</b>



Modification	Reason
<p>7. Water proof // strong // nylon // canvas // <b>kalis air / kuat / nilon / kanvas</b></p>	<p>8. to avoid the sail absorbs water // avoid sail become heavier // sail lighter // not easy to tear off // <b>elak layar serap air / elak layar jadi berat / layar ringan / tidak mudah koyak</b></p>
<p>9. Wide sail // big sail // <b>layar besar</b></p>	<p>10 bigger force // <b>daya lebih besar</b></p>



## Section C - 2015

Diagram 9.1 and Diagram 9.2 show two toy boats are separated at two different distances to each other due to the difference in pressure. In Diagram 9.1, the end of the rubber hose is pressed to reduce the size of the hose nozzle.

Rajah 9.1 dan Rajah 9.2 menunjukkan dua bot mainan terpisah pada dua jarak berbeza antara satu sama lain disebabkan oleh perbezaan tekanan. Dalam Rajah 9.1, bahagian hujung hos getah dipicit untuk mengurangkan saiz muncung hos.

- (a) What is the meaning of pressure?  
Apakah yang dimaksudkan dengan tekanan?

**Force per unit area //  
force/area**

**Daya per unit luas  
Daya/luas**

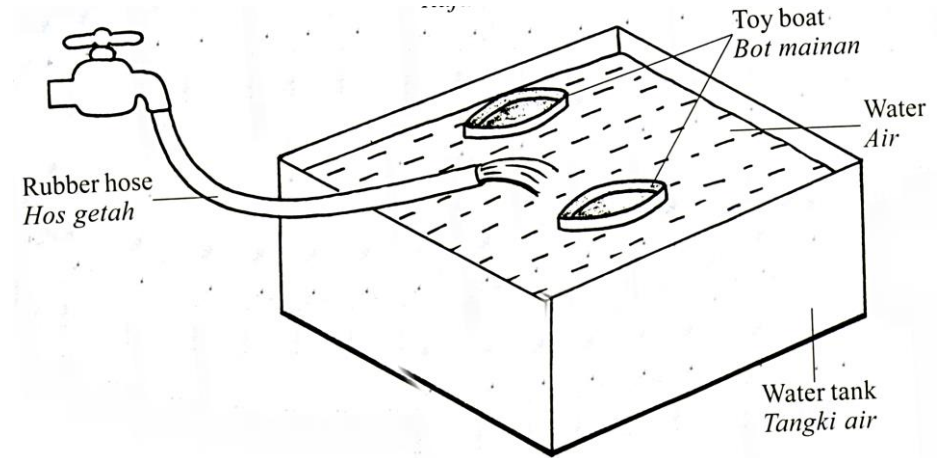
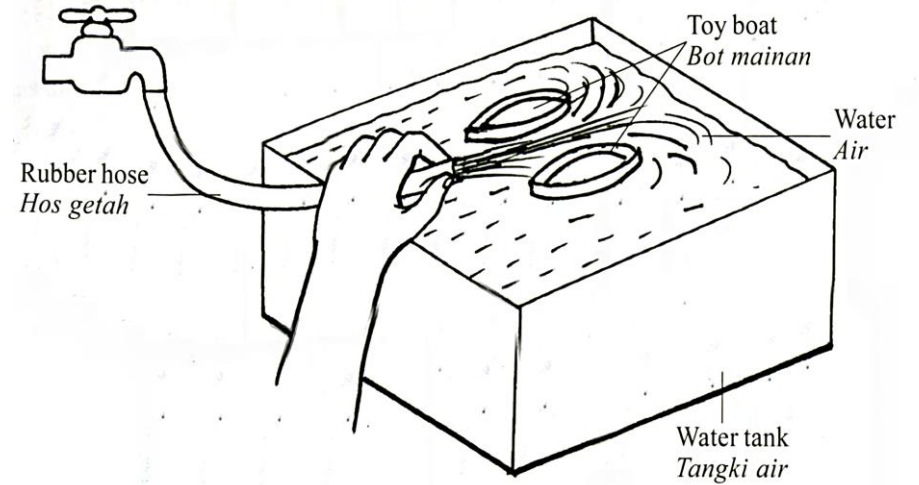

[1 mark]



- (b) (i) Using Diagram 9.1 and Diagram 9.2, compare the speed of water spurting out from the rubber hose and the distance of separation between the toy boats.

*Menggunakan Rajah 9.1 dan Rajah 9.2, bandingkan laju pancutan air dari hos getah dan jarak pemisahan antara bot-bot mainan itu.*

[2 marks]

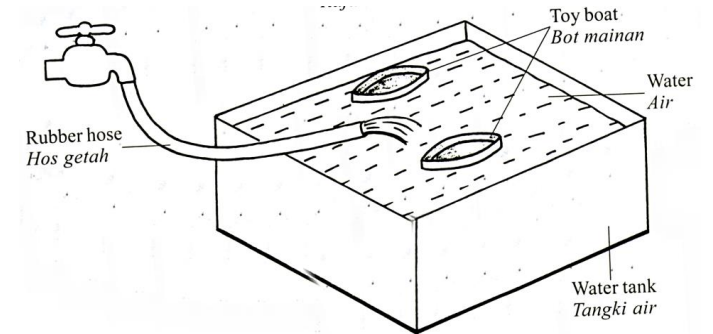
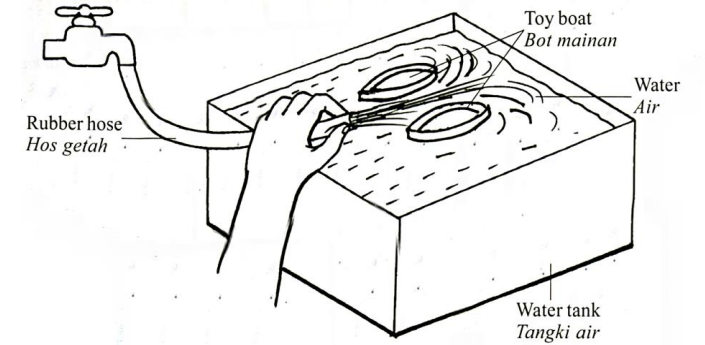

- **Speed of water that spurst out: 9.1 > 9.2**  
**laju pancutan air: 9.1 > 9.2**
- **The distance of separation between the two toy boats: 9.1 < 9.2**  
**jarak pemisahan antara bot-bot mainan: 9.1 < 9.2**



(ii) State the relationship between the speed of water spurting out and the distance of separation between the toy boats to make a deduction regarding of relationship between the speed of water and pressure.

*Nyatakan hubungan antara laju pancutan air dan jarak pemisahan antara bot-bot mainan itu untuk membuat deduksi tentang hubungan antara laju air dan tekanan.*

[2 marks]

- **The higher the speed of water, the shorter the distance of separation**  
**Semakin laju air, semakin dekat jarak pemisahan antara bot-bot**
- **The higher the speed of water, the lower the pressure**  
**semakin tinggi laju air, semakin rendah tekanan**

(iii) Name the physics principles involved.

*Namakan prinsip fizik yang terlibat.*

[1 mark]

**Bernoulli's principle**  
**Prinsip Bernoulli**



(c) Diagram 9.3 shows a cross section of a Bunsen burner.

*Rajah 9.3 menunjukkan keratan rentas satu penunu Bunsen.*

- **The gas from the gas tank flow in the bunsen burner / gas dari tangki gas mengalir ke penunu bunser**
- **At the nozzle, the velocity of gas flows is very high halaju gas mengalir laju di muncung**
- **A region of low pressure is produced at the nozzle Kawasan tekanan rendah dihasilkan di muncung**
- **Difference in pressure / perbezaan tekanan**
- **Air is sucked in / udara disedut masuk**
- **The mixture of gas and air producing complete combustion of gas / campuran udara dan gas hasilkan pembakaran lengkap**

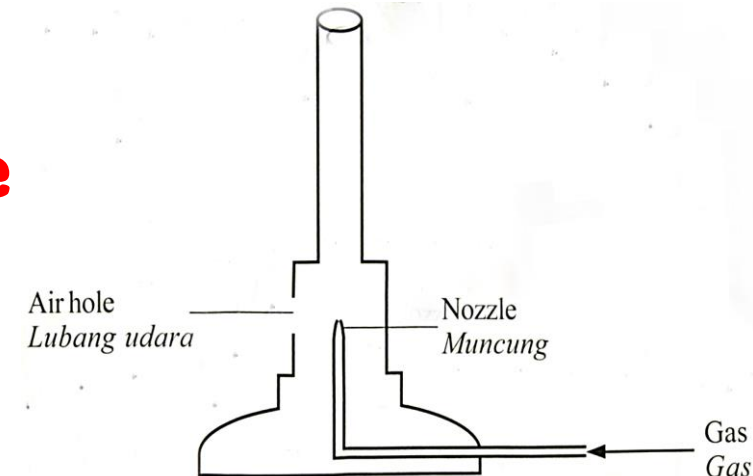

**(d) Diagram 9.4 shows a hydrometer which is used to measure density of a liquid.**

**You are required to modify the design in Diagram 9.4 so that the hydrometer is more sensitive and can measure wider range of liquid's density.**

**State and explain the modifications based on the following aspects:**

**(i) Length of the stem**

**(ii) Material of the hydrometer**

**(iii) Diameter of the stem**

**(iv) Size of the bulb**

**(v) Number of lead shots**

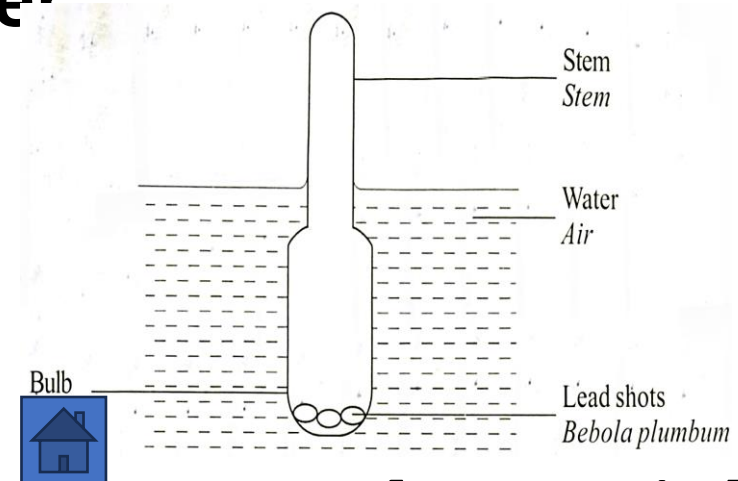

**[10 marks]**

- **Longer / panjang**
- **Wide / big range // sensitive // small scale division / julat besar / lebih peka / skala lebih kecil**
- **Plastic // glass / plastic / kaca**
- **Avoid corrosion / elak hakisan asid**
- **Small diameter // narrow / diameter kecil / sempit**
- **increase sensitivity / detect small change / lebih peka / kesan perubahan kecil**
- **Big bulb / bebuli besar**
- **Bouyant force / more weight of water displaced / daya apungan tinggi / lebih banyak air disesarkan**
- **More number of lead shorts / banyak bilangan butir2 plumbum**
- **Stable // balance / terapung tegak / lebih stabil**

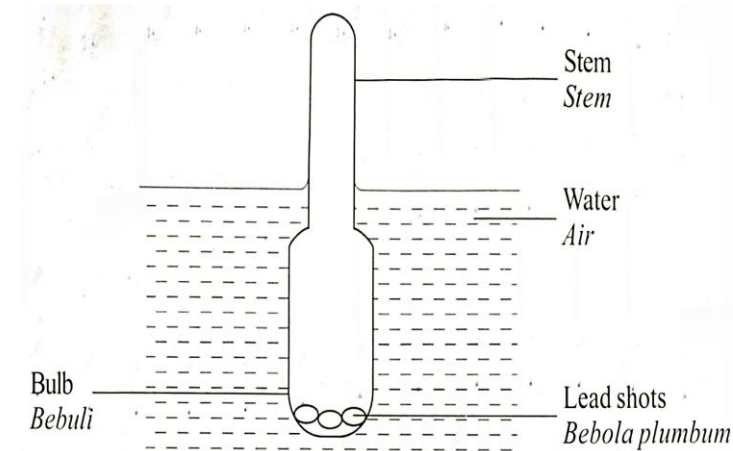

## SECTION C - 2021

1. Rajah 11.1 menunjukkan sebuah hidrofoil yang mengandungi sebuah papan luncur dengan sebuah hidrofoil yang disambung di bawahnya. Apabila papan hidrofoil bergerak, bentuk hidrofoil itu menyebabkan papan itu terangkat dari permukaan air disebabkan oleh Prinsip Bernoulli.

*Diagram 11.1 shows a hydrofoil board that contains a surfboard with a hydrofoil that is attached below it. When the board moves, the shape of the hydrofoil causes the board is lifted from the surface of the water due to the Bernoulli's principle.*

- (a) Nyatakan Prinsip Bernoulli. [1 markah]  
State the Bernoulli's principle [1 mark]

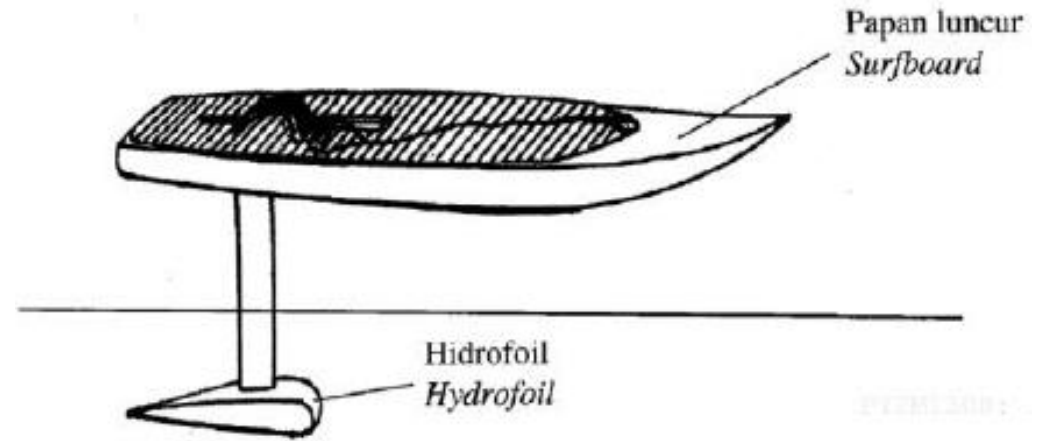

**Apabila laju bendalir bertambah, tekanannya berkurang // When the speed of liquid increases, its pressure decreases.**



(b) Terangkan bagaimana hidrofoil boleh menyebabkan papan itu terangkat apabila papan itu bergerak ke depan.

[4 markah]

*Explain how the hydrofoil can cause the board is lifted when the board moves forward.*

[4 marks]

**M1: Laju air di bahagian atas hidrofoil bertambah // Laju air atas bertambah / The speed of water at upper part of the hydrofoil increases. // Speed water upper / above increases / vice versa**

**M2: Tekanan air di bahagian bawah hidrofoil bertambah // Tekanan bawah bertambah**

**The pressure of water at lower part of hydrofoil increases // Pressure lower / below increases**

**M3: Perbezaan tekanan / Difference in pressure**

**M4: Daya angkat / Lift force**

**M5: Daya angkat > berat / Lift force > weight**



(c) Rajah 11.2 menunjukkan sebuah papan luncur bermotor tanpa hidrofoil bergerak selama 5 s.

*Diagram 11.2 shows a motorized surfboard without hydrofoil moves in 5 s.*

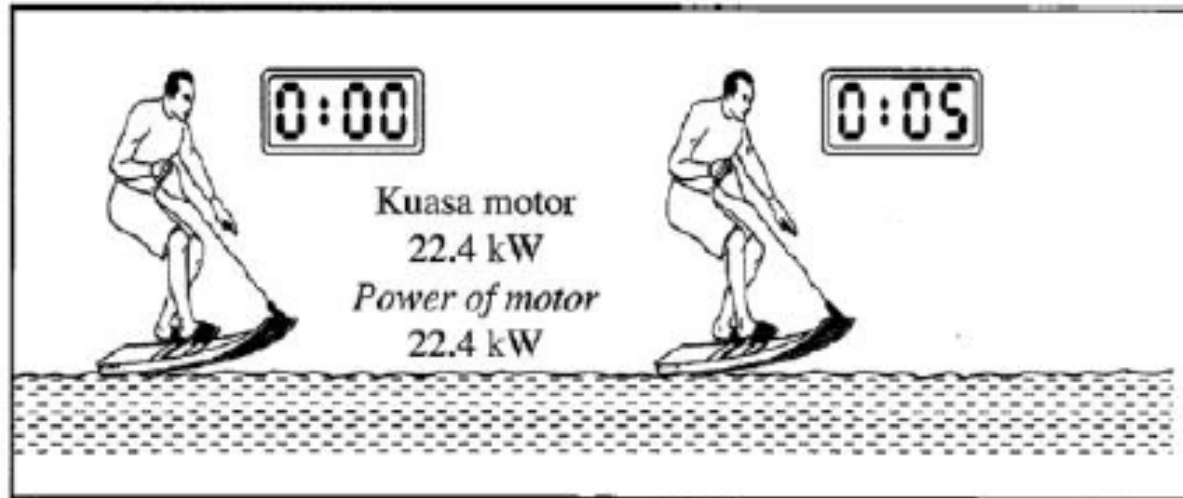

**Rajah 11.2 / Diagram 11.2**

Rajah 11.3 menunjukkan sebuah papan luncur bermotor yang mempunyai hidrofoil bergerak selama 5 s.

*Diagram 11.3 shows a motorized surfboard with hydrofoil moves in 5 s.*

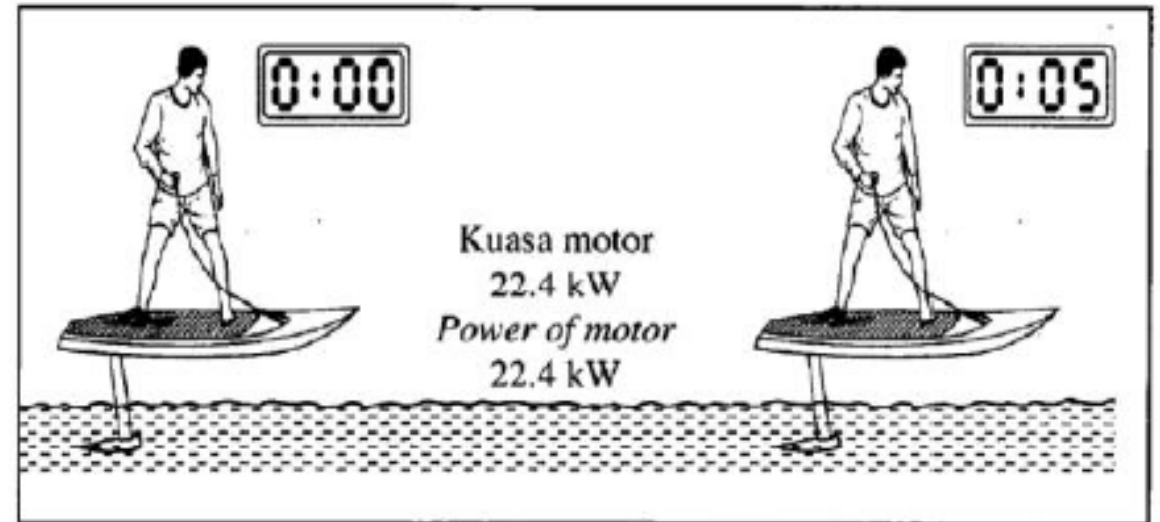

**Rajah 11.3 / Diagram 11.3**



Perhatikan Rajah 11.2 dan Rajah 11.3.  
Bandingkan ketinggian papan luncur dari permukaan air, daya geseran air yang bertindak ke atas papan luncur dan laju papan luncur itu.

*Hubungkan ketinggian papan luncur dari permukaan air dengan daya geseran air. Seterusnya, deduksikan hubungan antara daya geseran air dengan laju papan luncur itu.*

[5 markah]

*Observe Diagram 11.2 and Diagram 11.3. Compare the height of the surfboard from the water surface, water friction acted on the surfboard and the speed of the surfboard. Relate the height of the surfboard from the water surface and the water friction. Hence, deduce the relationship between the water friction and the speed of the surfboard.*

[5 marks]

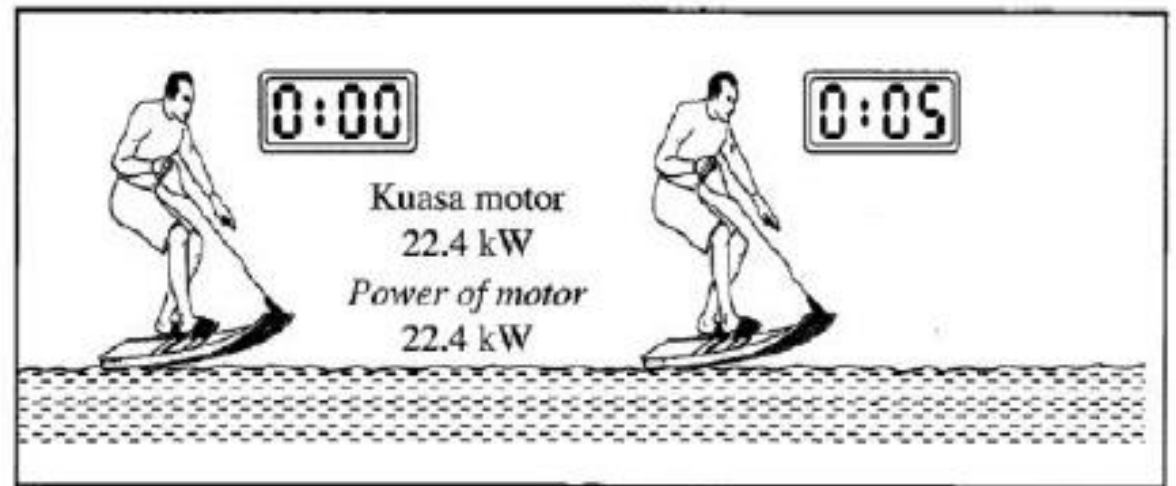

Rajah 11.2 / Diagram 11.2

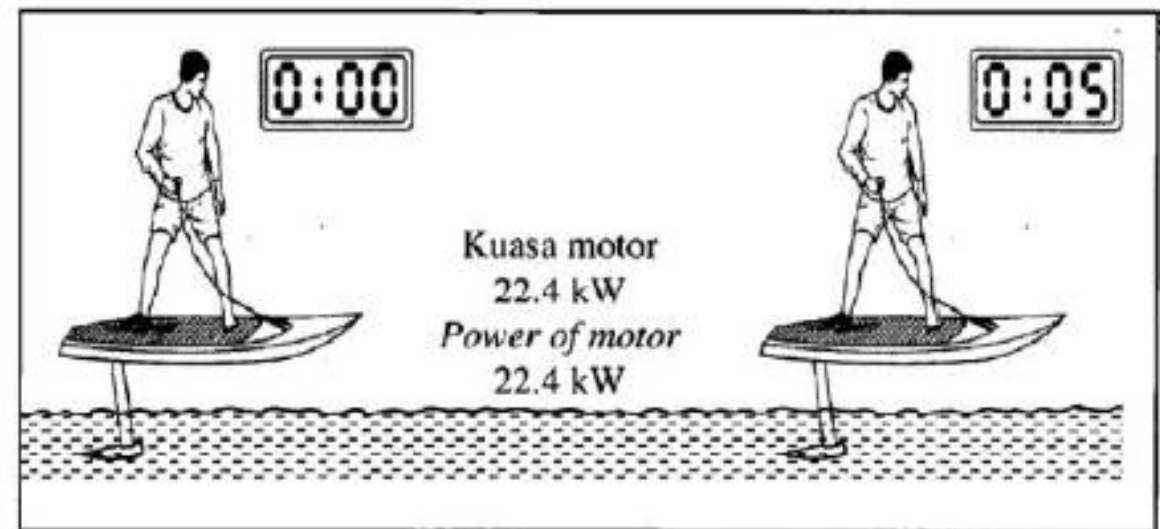

Rajah 11.3 / Diagram 11.3



- M1: Tinggi:  $11.3 > 11.2$  // Height  $11.3 > 11.2$**   
**M2: Geseran  $11.3 < 11.2$  / Friction  $11.3 < 11.2$**   
**M3: Laju  $11.3 > 11.2$  / speed  $11.3 > 11.2$**

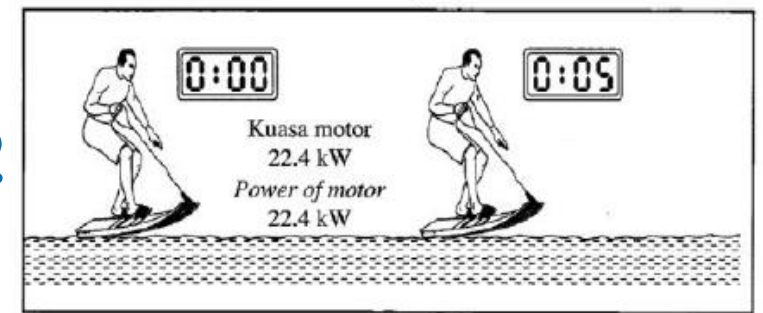

Rajah 11.2 / Diagram 11.2

- M4: Tinggi bertambah, geseran berkurang / Height increases, friction decreases, h berkadar songsang dengan geseran h inversely proportional to friction**  
**M5: Geseran berkurang, laju bertambah Geseran berkadar songsang dengan laju Friction decreases, speed increases Friction inversely proportional to speed**

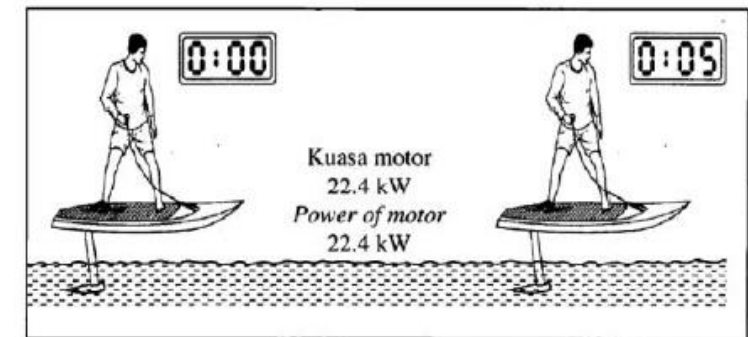

Rajah 11.3 / Diagram 11.3



(d) Rajah 11.4 menunjukkan sebuah bot hidrofoil yang bergerak di laut.

*Diagram 11.4 shows a hydrofoil boat moves in the sea.*

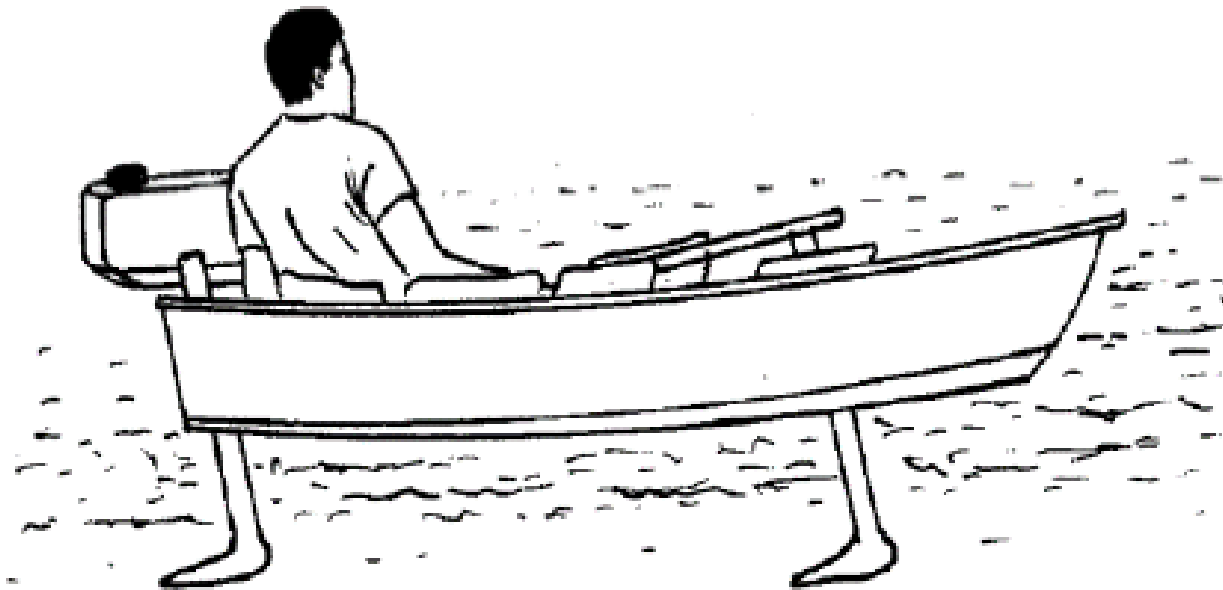

Rajah 11.4 / Diagram 11.4

Anda dikendaki merekacipta sebuah bot hidrofoil yang bergerak lebih cepat dan mampu membawa ramai penumpang dalam satu masa dengan selamat.

Nyatakan dan terangkan cadangan anda berdasarkan ciri dan saiz bot, ciri dan saiz hidrofoil, kuasa enjin yang digunakan dan bilangan hidrofoil yang disambungkan pada bot itu.

[10 markah]

*You are required to design a hydrofoil boat that can move faster and carry more passengers at the same time and safely. State and explain your suggestions based on the characteristics and the size of the boat, characteristics and the size of the hydrofoil, the power of engine used and the number of hydrofoil attached to the boat.*

[10 marks]



**M1**

**Ketumpatan bot rendah**

**Low density bot**

**M2**

**Ringan / light**

**Jisim rendah / low mass**

**Pecut / accelerate**

**M3**

**Bot kuat / strong boat**

**Bot kukuh**

**Bot aluminium**

**Bot keluli**

**Fibre plastic boat**

**Polyethylene boat**

**Carbon fibre boat**

**M4**

**Tidak pecah / not break**

**Tidak bocor / not leak**

**Strong / kuat / kukuh**

**Tahan karat / tidak karat /  
not rust**

**Lasting / tahan lama**

**Rej: tidak rosak / not  
damage / not break down**



**M5**

**Bot besar / big boat**

**Bot panjang**

**Bot luas / Bot lebar**

**Rej: bot tinggi**

**M6**

**Terapung / float / Daya apung  
besar / large buoyant force**

**$F_B$  besar /  $F_b$  besar,  $F_B >$**

**Banyak air tersesar / displaced  
more water.**

**M7**

**Hidrofoil besar / big  
hydrofoil / Hidrofoil luas**

**Rej: hidrofoil panjang / long  
hydrofoil / Hidrofoil lebar /  
wide hydrofoil / Hidrofoil  
tinggi / tall hydrofoil**

**M8**

**Daya besar / big force / big F**

**Daya (apung) besar / big lift force**



**M9:**

**Ketumpatan hidrofoil rendah**

**Low density hydrofoil**

**M10:**

**Ringan / light**

**Jisim rendah / low mass**

**Pecut / accelerate**

**M11:**

**Kuasa enjin besar**

**High power engine**

**M12:**

**Daya lebih / besar / pecut**

**Big thrust / big force / big F / accelerate**

**High momentum /**

**Tenaga tinggi / high energy / high E**

**Rej: Daya apung besar / daya angkat besar**



**M13:**

**Hidrofoil lebih / banyak**

**More hydrofoil**

**M14 Daya lebih / besar**

**More force / more lift**

**Kuasa lebih / tenaga lebih**

**Momentum lebih / Daya apung  
besar / Daya angkat besar**

**M15**

**Jisim bot kecil / Small mass of  
boat / Bot ringan / light boat**

**M16 Pecut / accelerate**

**M17**

**Low mass of hydrofoil**

**Jisim hydrofoil kecil**

**Hidrofoil ringan / light  
hydrofoil**

**M18 Pecut / accleratate**



**M19**

**Bot aerodinamik**

**Bot larus / streamline boat**

**M20**

**Kurang geseran / low friction / Kurang rintangan / low resistance**

**Kurang seretan / low drag**

**M21**

**Hidrofoil kuat / kukuh**

**Hidrofoil aluminium**

**Hidrofoil keluli / steel**

**Hidrofoil fibre plastic**

**Hidrofoil polyethylene**

**Hidrofoil carbon fibre**

**M22**

**Tidak pecah / not break**

**Strong / kuat / kukuh**

**Tahan karat / tidak karat**

**Not rust**

**Rej: tidak bocor**

